



Thank you for purchasing KOSO's Harley Davidson Oil Pressure Meter. Before operating this unit, please read the instructions thoroughly and retain them for future reference.

## ⚠ Notice

1. This meter only function with DC 12V.
2. Any damages caused by faulty installation shall be imputed to the users.
3. To avoid a short circuit from occurring, do not pull or modify the wires during installation.
4. Dissassembling this unit will void your warranty. Maintenance and repairs should be executed by Professionals only.

## SYMBOL MEANING:

⚠ Some procedures must be followed in order to avoid faulty installation.

**⚠ WARNING!** Some procedures must be followed to avoid damages from occurring to yourself and others.

**⚠ CAUTION!** Some procedures must be followed to avoid damages from occurring to the vehicle.



FLASH



LIGHT ON



PRESS THE  
BUTTON ONE  
TIME



PRESS THE  
BUTTON 3  
SECONDS

## 1 Accessories

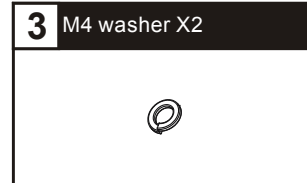
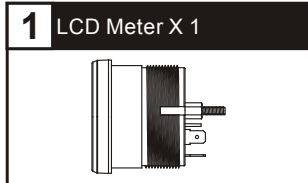

**NOTE** Please contact your local distributor if the items received are not the same as the items listed above.

## 2-1 Gauge location

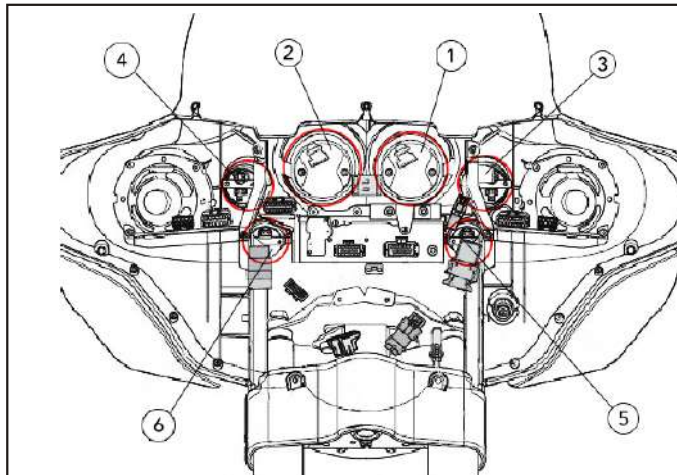

- ① HD-02S 4" Speedometer
- ② HD-02R 4" Tachometer
- ③ HD-02T 2" Ambient Temp. Meter
- ④ HD-02V 2" Voltage Meter
- ⑤ HD-02F 2" Fuel Meter
- ⑥ HD-02P 2" Oil Pressure Meter

**NOTE** Gauge positioning and identification for 2004-2013 Harley-Davidson FLHT / FLHX / FLTR. For any other models, refer to the service manual.

## 2-2 Disassembling Instructions



1. Disconnect the ground (-) (negative pole of the battery) from the vehicle's battery.



2. Remove the mounting screw and remove the fairing.



3. Disconnect the headlight connector.



5. Remove the mounting hardware.

6. Remove the meter from the inner fairing.



4. Disconnect the wiring from the Speedometer, tachometer, ambient temp. meter, volt meter, fuel meter, and oil pressure meter.

7. Replace the meter with the new KOSO version.

**NOTE** The installation will be the same procedure backwards



## 4 Entering in the settings screen

\* To enter the gauge settings mode, you must follow the steps below :

- A : The key must be switched to ON/ACCESSORIES (1).
- B : The Engine OFF/Run must be OFF (2).
- C : The speedometer must be displaying ODOMETER (3).
- D : Press and hold the Trip/Reset button down for 3 seconds to enter the settings (4).
- E : Use the Trip/Reset button to navigate through the settings (4).

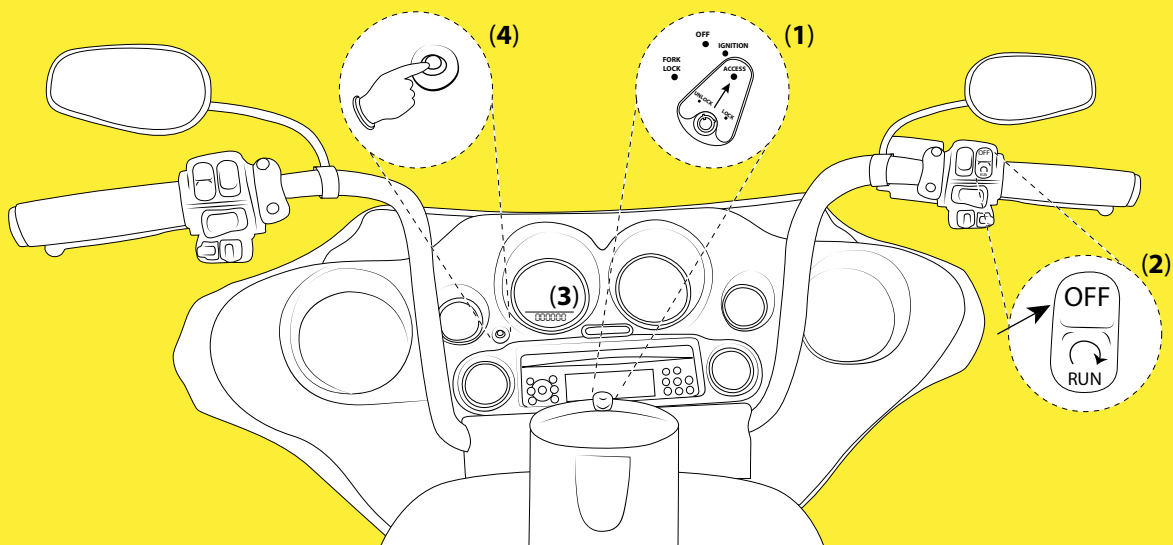

- ☒ In the main screen, hold the button for 3 seconds to enter into the settings screen.

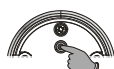

### 4-1 Oil Pressure warning settings screen

- ☒ Press the button to change the settings



- ☒ EX. The Oil Pressure warning is 15 PSI.
- ☒ Press and hold the button for 3 seconds to move to the digit you want to set.

⚠ Now the default is flashing

**NOTE** Default: 10 PSI

**NOTE** Setting range : 5~60 PSI



- ☒ EX. You want to set the Oil Pressure warning at 10 PSI to 15 PSI.
- ☒ Press and hold the button for 3 seconds to enter back into the main screen.



- ☒ Back to the main screen.



## 5 Troubleshooting

The following situations do not indicate malfunction of the meter. Please check the following points, before taking it in for repairs.

Trouble	Check item
The meter doesn't work when the power is on.	<ul style="list-style-type: none"> <li>☒ If there is no power being supplied to the meter.</li> <li>☒ Make sure the wires are connected and that the wiring and fuse are not broken.</li> <li>☒ The battery is broken or the battery is too old to supply enough power (DC 12V) to make the meter work.</li> </ul>