

INSTRUCTION



Thank for purchasing our T&T meter. Before operating this unit, please read carefully the instruction sheet and retain it for the future reference.

Notice

1. This meter work on DC 12 volts applications only.
2. For proper installation, please follow the steps described in the instruction. Any damages caused by wrong installation shall be imputed to the users.
3. Don't break or modify the wire terminal. To avoid any short circuit, do not pull the wires out of the terminal when installing.
4. Do not disassemble or change any parts.
5. Opening the instrument will void any warranty. Maintenance or repair should be executed by our professionals only.

MARK MEANING:

⚠ Some procedures must be followed to avoid damages to the instrument.

⚠ **WARNING!** Some procedures must be followed to avoid injuries to the user or others.

⚠ **CAUTION!** Some procedures must be followed to avoid damages to the vehicle.



Light on



Flash



Press the button one



Press the button for 3 seconds

1 Accessory

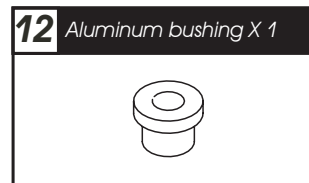
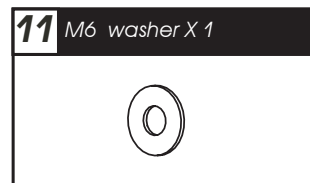
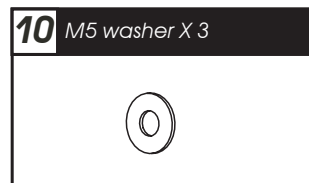
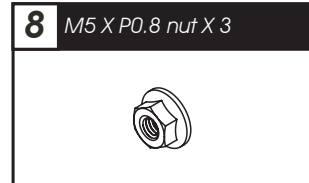
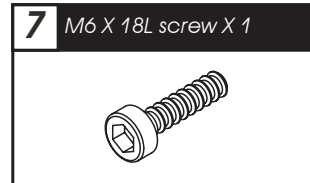
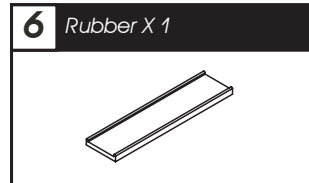
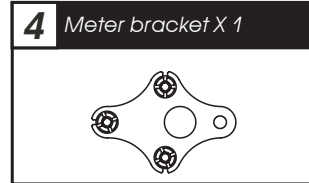
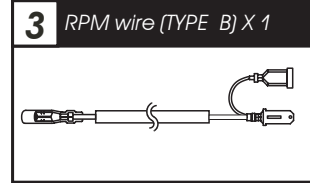
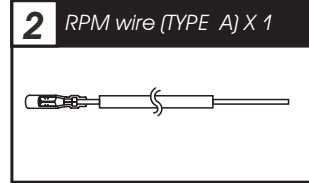
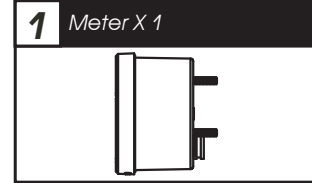

NOTE Please contact your local distributor if the items received in the box are not the same as the one listed above.

2 Wiring installation instruction

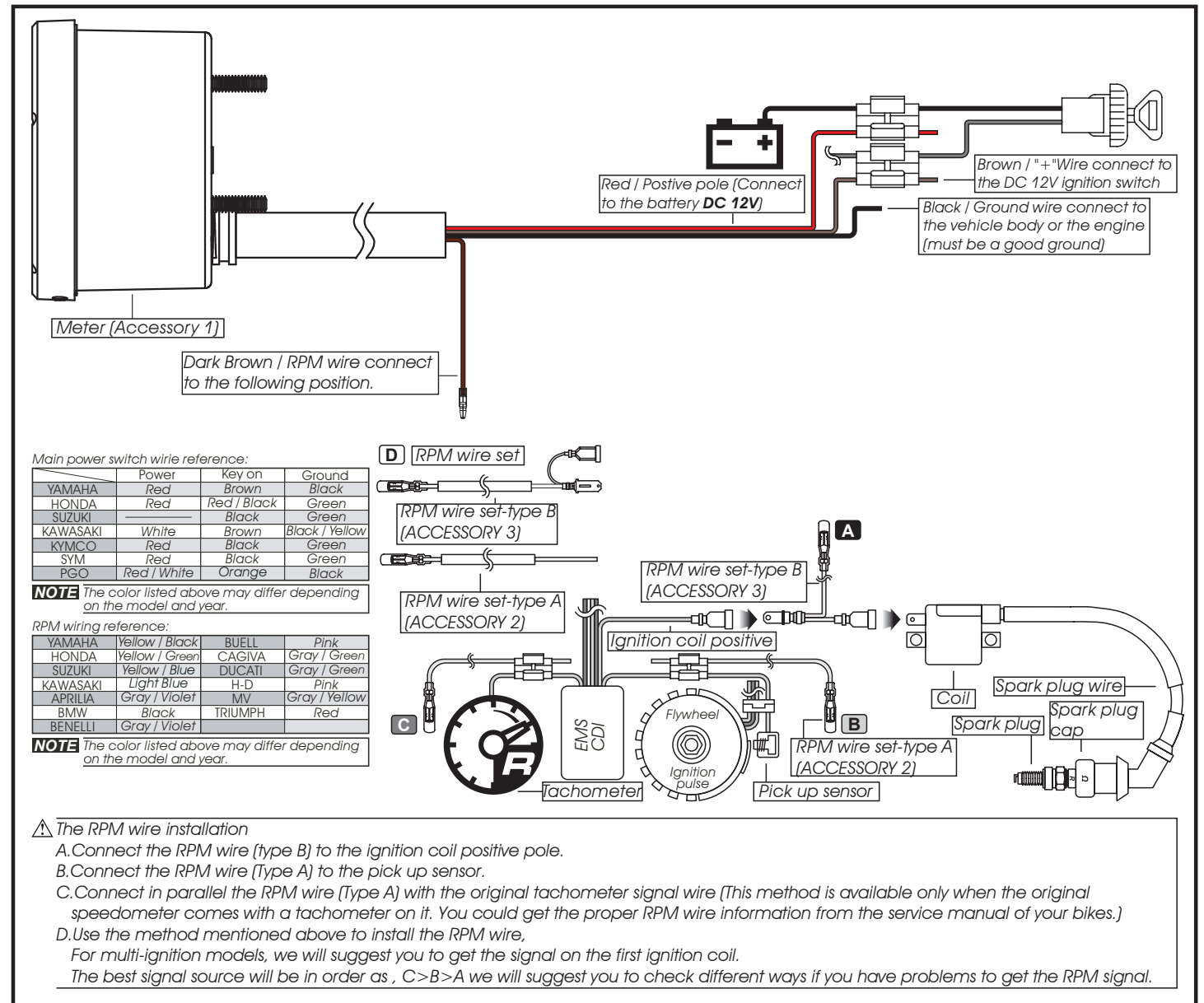

3-1 Basic function instruction

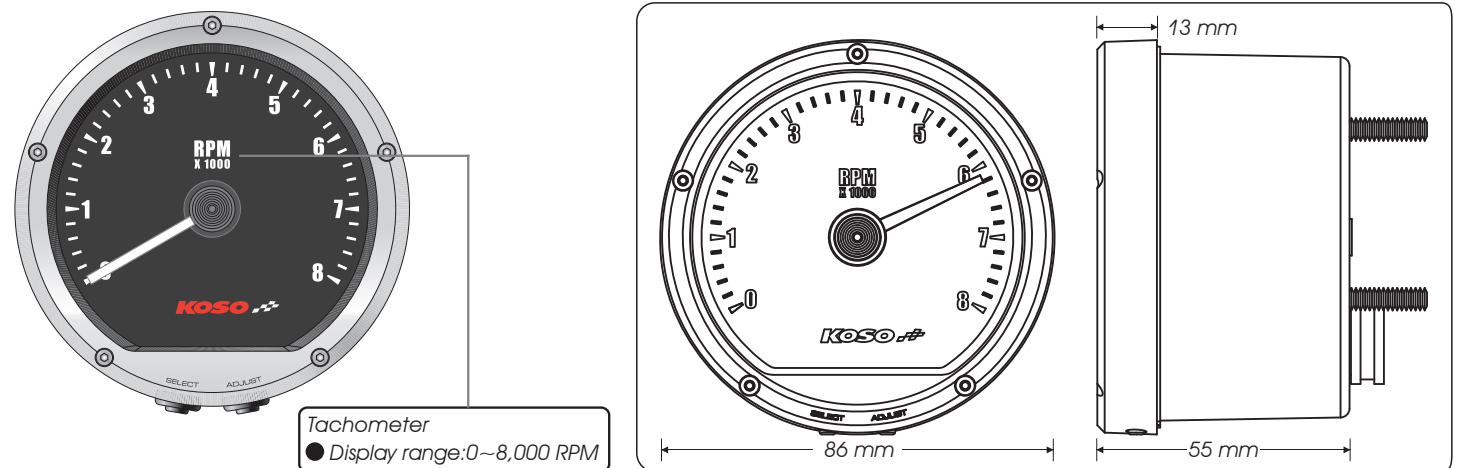

3-2 Specifications

● Tachometer	Display range: 0~8,000 RPM	● Effective voltage	DC 12V
○ Display interval	< 0.5 second	● Effective temperature range	-10~+60°C
○ The RPM input signal number setting	Setting range: 0.5, 1~6	● Meter standard	JIS D 0203 S2
○ The RPM input signal pulse	Setting range: Hi (positive wave pulse) Lo (negative wave pulse)	● Meter size	D86 X 55 mm
● Backlight brightness	Setting range: 6 different levels available. Setting unit: Each level represents 20%	● Meter weight	Around 330g

NOTE Design and specification are subject to change without notice.

4-1 Main function instruction (Operating mode)

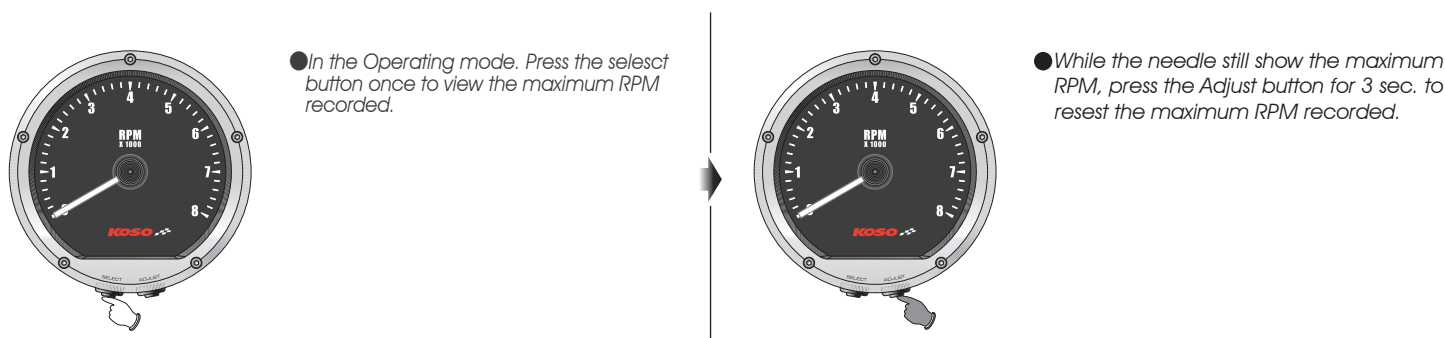

4-2 Setting steps

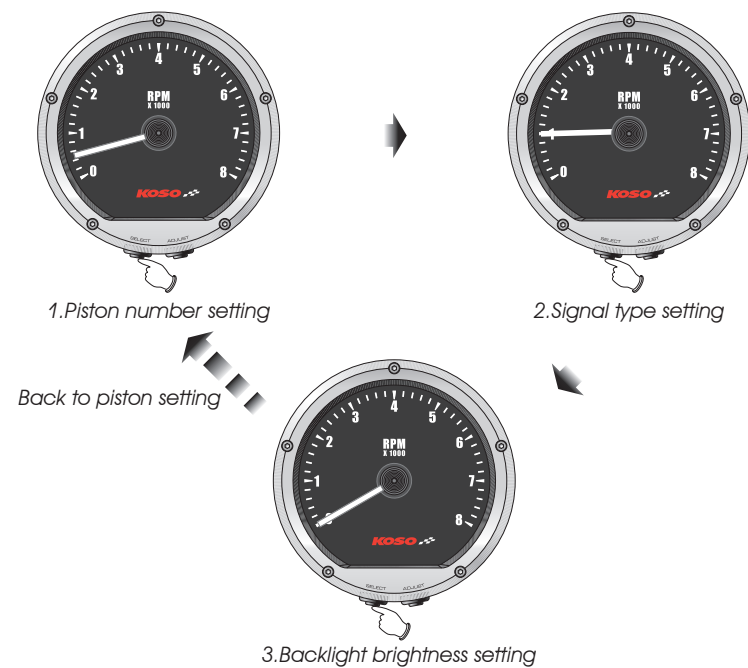

⚠ The instrument will automatically return to the operating mode after 10 seconds if no buttons has been pressed.

NOTE In the setting mode, press the select button for 3 seconds to enter the operating mode.

4-3 Entering setting mode



● In the operating mode, hold the Select & Adjust button for 3 seconds to enter the setting mode.

4-3-1 Piston number setting

● Press the Adjust button to change the default value.

NOTE The meter is set by default at 0.5 and Hi. This setting is made to fit most of the Harley® models when RPM signal come from one coil (see section 2)

setting value	2 Strokes setting	4 Strokes setting	RPM per spark
0.5	—	1 pist.	2 RPM signals per 1 spark.
1	1 pist.	2 pist.	1 RPM signal per 1 spark.
1.5	—	3 pist.	2 RPM signals per 3 spark.
2	2 pist.	4 pist.	1 RPM signal per 2 spark.
2.5	—	5 pist.	2 RPM signals per 5 spark.
3	3 pist.	6 pist.	1 RPM signal per 3 spark.
4	4 pist.	8 pist.	1 RPM signal per 4 spark.
5	—	10 pist.	2 RPM signals per 10 spark.
6	6 pist.	12 pist.	1 RPM signal per 6 spark.

⚠ **CAUTION!** Some 4 strokes engines with one piston are igniting every 360 degree. To get the proper RPM for such engines, the setting should be the same as 2 strokes engines with one piston.

● Press the Select button once to enter the signal type setting.

4-3-2 Signal type setting

● Press the Adjust button to change the value
1=Hi, 0=Lo

NOTE We define the RPM input pulse as Hi (positive pulse) & Lo (negative pulse).

NOTE If the RPM displayed on the meter is incorrect, choose another setting and try it again.

● Press the Select button once to enter the backlight brightness setting.

4-3-3 Backlight brightness setting

● Press the Adjust button to change the value.

NOTE Setting range: 0 (Darkest)~5 (Brightest), 6 different levels available.
Setting unit: 20% per level.
The backlight brightness will change immediately after you set the value.

● Press the Select button for 3 seconds to enter the operating mode.