



• Thank you for purchasing the our product. Before installing, please read the instruction carefully and keep it for future reference.

Notice

- Please, follow the step-by-step instructions for proper installation. Any damages caused by faulty installation shall be imputed to the users.
- To avoid a short circuit, do not pull the wires when installing the unit. Do not break or modify the wires either.
- Do not disassemble or change any parts.
- Maintenance and repairs should be executed by our professionals only.

©Mark Meaning:

NOTE You could get the installation details from the information behind the mark.

▲ Some processes must be followed to avoid the affection caused by wrong installation.

▲ WARNING! Some processes must be followed to avoid damages to yourself or the public.

▲ CAUTION! Some processes must be followed to avoid the damage to the vehicle.

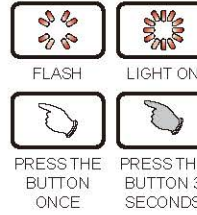

1-1 Accessories

1 Meter X 1	2 Main wiring harness X 1	3 RPM wire (TYPE A) X 1	4 RPM wire (TYPE B) X 1
5 Active speed sensor X 1	6 M8 / S type speed sensor bracket X 1	7 M10 / S type speed sensor bracket X 1	8 M5 X 5L mm Hexagon screw X 2
9 4 mm Allen key X 1	10 3 mm Allen key X 1	11 2 mm Allen key X 1	12 M5 X 12L screw X 2
13 M4 X 10L screw X 2	14 M4 washer X 2	15 Meter bracket X 1	

NOTE Contact your local distributor, if the items received in the box are not the same as the items listed above.

1-2 Accessories

1 Digital speed signal sensor JIS TYPE A	2 Digital speed signal sensor RUNNER	3 Digital speed signal sensor SR X-FIGHT BOOSTER	4 L TYPE speed sensor bracket
5 Meter bracket			

NOTE Some of the optional accessories may not be available in your area. Contact your local distributor to obtain more information.

2-1 Wiring installation instructions

Main power switch wire reference:

	Power	Key on	Ground
YAMAHA	Red	Brown	Black
HONDA	Red	Red / Black	Green
SUZUKI		Black	Green
KAWASAKI	White	Brown	Black / Yellow
KYMCO	Red	Black	Green
SYM	Red	Black	Green
PGO	Red / White	Orange	Black

RPM wire reference:

	Power	Key on	Ground
YAMAHA	Yellow / Black	BUELL	Pink
HONDA	Yellow / Green	CAGIVA	Gray / Green
SUZUKI	Yellow / Blue	DUCATI	Gray / Green
KAWASAKI	Light Blue	H-D	Pink
APRILIA	Gray / Violet	MV	Gray / Yellow
BMW	Black	TRIUMPH	Red
BENELLI	Gray / Violet		

Fuel indicator wire reference:

	Power	Key on	Ground
YAMAHA	Green	KYMCO	Yellow / White
HONDA	Yellow / White	SYM	Yellow / White
SUZUKI	Yellow / White	PGO	Gray
KAWASAKI	Black / L Green		

NOTE The color listed above may differ depending on the model and year.

NOTE When connecting the power wire, please follow carefully the instruction. If the red & brown wires are connected in parallel, the meter won't work properly.

NOTE Motor oil indicator can be set up, install as two stroke motor oil indicator, or other positive(+12V) or negative actions' indicator.

▲ The RPM wire installation
We recommend installing the R type spark plug or low-resistance spark plug cap at the same time.
A. Connect the RPM wire (Type A) on the spark plug wire by connecting the male and female connectors.
B. Connect the RPM wire (Type B) to the pick up sensor.
C. Connect in parallel the RPM wire (Type A) with the original tachometer signal wire.
The best signal source will be in order as C>B>A, we will suggest you to check different ways if you have problems to get the RPM signal.

2-2 Installation instruction

When installing, please follow the steps below.

1. M5 x 12L screw x2 (Accessories 13)
2. Meter bracket for handle bar (Accessories 12)
3. Fix the bracket on handle bar (7/8 inch)
4. Bracket x1 (Accessories 12)
5. Meter (Accessories 1)
6. Meter board (Accessories 12)
7. M4 washer x2 (Accessories 15)
8. M4 x 10L screw x2 (Accessories 14)





NOTE Adjust the meter to the proper angle before tightening the handle bar bracket screws.

Special instruction for meter fix board.



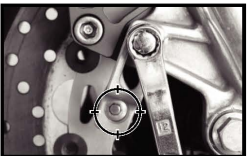

A. Push meter bracket clip up to lock meter fix board (with meter) on bracket

B. Push meter bracket clip down to release meter fix board (with meter) on bracket

MOTO / SCOOTER S type speed sensor bracket instruction

	Install the S type sensor bracket.		Install the speed sensor on the bracket.
	Adjust the sensor bracket position to make sure that the sensor could face the magnet to prevent bad speed signal or no signal!		Adjust the distance between sensor and magnet. We suggest you to make sure the distance is under 1 mm for catching good speed signal.

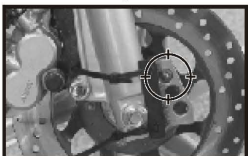
MOTO / SCOOTER L type speed sensor bracket instruction

	Please install the L bracket and the anti-slip rubber on the front fork and adjust it to the proper height and angle.		Install the speed sensor on the bracket.
	Please use the cable tie to fix the bracket on the front fork. Please make sure the disc screw could pass the hole on the bracket for you to install the sensor into the same hole for catching the speed signal.		Adjust the distance between sensor and magnet. We suggest you to make sure the distance is under 1 mm for catching good speed signal.



The active speed sensor could be installed by the metal parts to detect the speed.

- EX. 1 The disc screw.
 EX. 2 The disc to detect the disc gap. (Please make sure the distances between the gaps are the same in advance to avoid wrong speed signal.)
 EX. 3 The sprocket to detect the disc gap. (Please make sure the distances between the gaps are the same in advance to avoid wrong speed signal.)
 EX. 4 Rear disc - detect the gap between the disc.

We will suggest you to catch the speed from the disc screws. The more the sensor points are, the better the speed accuracy is. The maximum sensor points the speed sensor could detect is 20 points per turn.

⚠ After installation, please use your hand to turn the tire to see is everything ok. The LED on the active speed sensor will light up once the signal is detected.

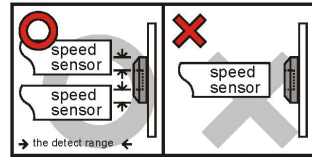
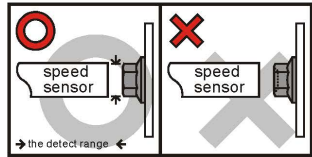
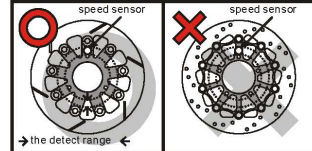
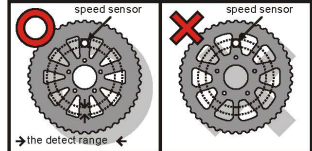
	EX. 1 The hexagon socket disc screw The best detect area: The edge of the hexagon socket screw. ⚠ Please don't catch the signal from the middle hole of the hexagon socket screw to avoid wrong signal.		EX. 2 The hexagon screw The best detect area: The middle of the screws. ⚠ Some hexagon screw center is with a small hole in the center. In this case, we will suggest you to catch the signal from the edge of the screw like the hexagon socket screw.
	EX. 3 The disc The best detect area: Please detect the speed signal from the gaps of the disc. ⚠ Please note that there are discs with the gaps in different difference, and this method will not work on it!		EX. 4 The sprocket The best detect area: Please detect the speed signal from the gaps of the sprocket. ⚠ Please note that there are sprockets with the gaps in different difference, and this method will not work on it!

3-1 Basic function instruction

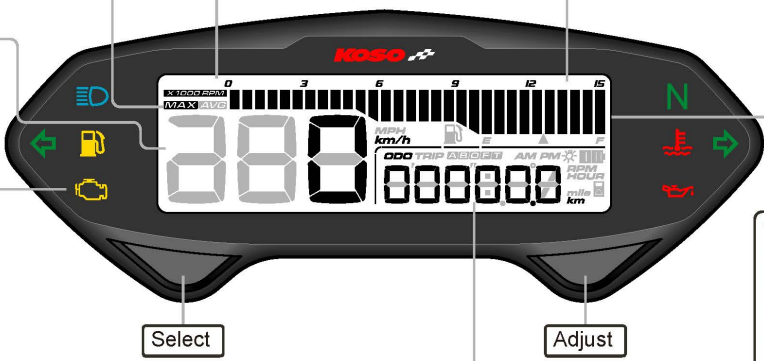

Maximum speed record ● Display range : 0 ~ 360 km/h (0 ~ 225 mile) Maximum RPM record ● Display range : 0 ~ 15,000 RPM	Average speed record ● Recording range : 0 ~ 360 km/h (0 ~ 225 MPH)	Tachometer ● Display range : 0 ~ 10,000 RPM \ 0 ~ 12,000 RPM \ 0 ~ 15,000 RPM	Fuel Level ● Setting range : 100Ω \ 250Ω \ 270Ω \ 510Ω \ 1200Ω \ SWITCH \ USER Low fuel warning ● Setting range : 10 ~ 50%, when lower than (including) setting value, fuel level symbol will blink.
Speedometer ● Display range : 0 ~ 360 km/h (0 ~ 225 mile)			
Indication light ● Neutral (green light) N ● Right indication light (green light) → ● Water temperature (red light) ̳ ● Motor oil (red light) ̳ ● Engine (yellow light) ̳ ● Fuel (yellow light) ̳ ● Left indication light (green light) ← ● High beam light (blue light) ̳	Select	Adjust	Total engine operating time ● Display range : 0~99,999.9 hours ● Display unit : 0.1 hour Engine operating time A,B ● Display range : 0~9,999.9 hours ● Display unit : 0.1 hour
Odometer ● Display range : 0 ~ 99999.9 km (mile), return to zero upon exceed. ● Display unit : 0.1 km (mile)	Voltmeter ● Display range : DC 8.0 V ~ 16.0 V ● Display unit : 0.1 V	Internal ODO ● Display range : 0 ~ 99,999.9 km (mile), user unadjustable. ● Display unit : 0.1 km (mile)	
Trip meter A \ B ● Display range : 0 ~ 999.9 km (mile), return to zero upon exceed. ● Display unit : 0.1 km (mile)	Clock format ● Setting range : 12 - hrs format, 24 - hrs format.	External ODO ● Setting range : 0 ~ 99,999 km (mile) ● Setting unit : 1 km (mile)	
Tachometer ● Display range : 0 ~ 15,000 RPM ● Display unit : 10 RPM	Clock ● Setting range : 0 : 00 ~ 23 : 59 (24 - hrs format), 1 : 00 ~ 12 : 59 (12 - hrs format)	Motor oil maintenance millage ● Display range : SI unit : 500 (~ 8,000 km, user adjustable) ~ -999 km, automatic decrease according to the increase of total millage. ● Display range : Inch : 300 (~ 5,000 mile user adjustable) ~ -999 mile, automatic decrease according to the increase of total millage. ● Display unit : 1 km (mile)	

3-2 Function, setting instructions

● Speedometer	Display range : 0 ~ 360 km/h (0 ~ 225 MPH) Will blink when exceed range. Display unit : 1 km (mile)	● Fuel level	Setting range : 100Ω \ 250Ω \ 270Ω \ 510Ω \ 1200Ω \ SWITCH \ USER
○ Display internal	<0.5 second	○ Staged fuel gauge	Setting range : 10 stage display Warning range : Fuel level warning stage below (including) setting value, fuel level symbol will blink.
○ Odometer	Display range : 0 ~ 99,999.9 km (mile), return to zero upon exceed. Display unit : 0.1 km (mile)	○ Digital fuel gauge	Setting range : 0 ~ 100 % Setting unit : 10 %
○ Trip meter A \ B	Display range : 0 ~ 999.9 km (mile), return to zero upon exceed. Display unit : 0.1 km (mile)	○ Low fuel warning	Setting range : 10 ~ 50 %, when lower than (including) setting value, fuel level symbol will blink. Setting unit : 10 %
● Motor oil maintenance millage	Display range : SI unit : 500 (~ 8000 km, user adjustable) ~ -999 km, automatic decrease according to the increase of total millage. Display range : Inch : 300 (~ 5000 mile user adjustable) ~ -999 km, automatic decrease according to the increase of total millage. Display unit : 1 km (mile)	● Volt meter	Display range : DC 8.0 V ~ 16.0 V Display unit : 0.1 V
○ Maximum speed record	Display range : 0 ~ 360 km (0 ~ 225 mile) Display unit : 1 km (mile)	● Clock format	Setting range : 12-hrs format, 24-hrs format
○ Average speed record	Recording range : 0 ~ 360 km/h (0 ~ 225 MPH)	○ Clock (hours)	Setting range : 0 ~ 23 (24-hrs format), 1 ~ 12 (12-hrs format) Setting unit : 1 hour
○ Tire circumference	Setting range : 300 ~ 2,500 mm Setting unit : 1 mm	○ Clock (minute)	Setting range : 00:59 minutes Display range : 1 minute
○ Sensitive point	Setting range : 1 ~ 20 points Setting range : 1 point	● Internal ODO	Display range : 0~99999.9 km (mile), user unadjustable Display unit : 0.1 km (mile)
● Tachometer	Display range : 0 ~ 15,000 RPM Display unit : 10 RPM	● External ODO	Setting range : 0~99999 km (mile) Setting unit : 1 km (mile)
○ Display internal	<0.5 second	● Backlight color	Display range: white
○ Stage tachometer	Display range : 0 ~ 10,000 RPM \ 0 ~ 12,000 RPM \ 0 ~ 15000 RPM Display unit : 0 ~ 10,000 RPM (333 RPM each stage) 0 ~ 12,000 RPM (400 RPM each stage) 0 ~ 15,000 RPM (500 RPM each stage)	● Effective voltage	DC 12 V
○ MAX RPM record	Display range : 0 ~ 15,000 RPM Display unit : 10 RPM	● Effective temperature range	+60 °C
○ The RPM input signal number setting	Setting range : P-0.5, P-1~P-25	● Meter standard	JIS D 0203 (S2)
○ The RPM input pulse	Setting range : lo-Act, Hi-Act	● Meter size	120 x 46 x 20 mm
● Total hour meter	Display range : 0 ~ 99,999.9 hours Display unit : 0.1 hour	● Meter weight	Around 240 g
○ Hour meter A \ B	Display range : 0 ~ 9,999.9 hours Display unit : 0.1 hour	● Indicator light	Neutral (green light) N Right indication light (green light) → Water temperature (red light) ̳ Motor oil (red light) ̳ High beam light (blue light) ̳ Left indication light (green light) ← Fuel (yellow light) ̳ Engine (yellow light) ̳

NOTE Any design and specification changes will not be notify.

3-3 Meter size

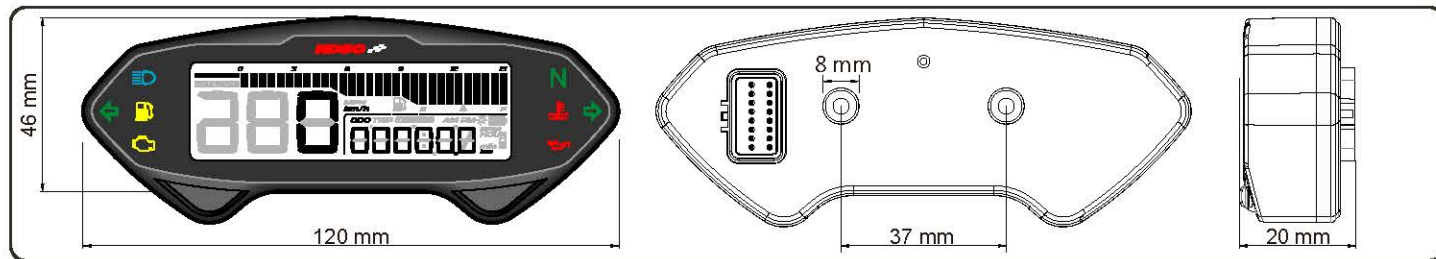

3-4 Select button function instruction

- In the clock screen, press the **Select** button one time to enter the volt screen.
- In any screen, press and hold the **Select** buttons for 3 seconds to switch between rpm and fuel bar screen.
- In the volt screen, press the **Select** button one time to enter the fuel level screen.
- In the fuel level screen, press the **Select** button one time to go back to the clock screen.
- In the clock screen.

3-5 Adjust button function instruction

- In the ODO screen, press the **Adjust** button to enter the Trip A screen.
- In the ODO screen, press the **Select+Adjust** buttons for 3 seconds to enter settings (Please refer to 4).
- In the Trip A screen, Press the **Adjust** button to enter the Trip B screen.
- Press and hold the **Adjust** button for 3 seconds to reset Trip A screen.
- In the Trip B screen, press the **Adjust** button to enter the oil maintenance mileage screen.
- Press and hold the **Adjust** button for 3 seconds to reset Trip B screen.
- In the oil maintenance mileage screen, press the **Adjust** button to enter the total hour meter screen.
- Press and hold the **Adjust** button for 3 seconds to reset oil maintenance mileage screen.
- In total hour meter screen, press the **Adjust** button to enter the hour meter A screen.
- In the hour meter A screen, press the **Adjust** button to enter the hour meter B screen.
- Press and hold the **Adjust** button for 3 seconds to reset hour meter A screen.
- In the hour meter B screen, press the **Adjust** button to enter the Max. record screen.
- Press and hold the **Adjust** button for 3 seconds to reset hour meter B screen.
- In the Max. record screen, press the **Adjust** button one time to enter the Average speed record screen.
- Press and hold the **Adjust** button for 3 seconds to reset Max. record screen.
- In the Average speed record screen, press the **Adjust** button one time to enter the ODO screen.
- Press and hold the **Adjust** button for 3 seconds to reset Average speed record screen.
- In the ODO screen.

3-6 The settings screen description

- Total mileage screen - Press and hold the **Select + Adjust** button for 3 seconds to enter setting screen.
- Press the **Adjust** button to select setting screen for Circumference and sensing pointsetting, RPM pulse setting, Fuel gauge resistance setting (Fuel level manual setting / Fuel level resistance auto detection setting / Fuel warning setting), Clock setting, Backlight brightness setting, Oil maintenance mileage setting, Speed unit setting, External ODO, Internal ODO.
- In any setting screen, hold the **Select** button for 3 seconds to return to main screen.
- NOTE** In settings screen, button is not pressed in 30 seconds, or speed > 3 km/h, will automatically return to main screen.
- NOTE** After exiting settings screen, it will record the parameters.

4 Enter settings and function index menu

- Press and hold the **Select + Adjust** button for 3 seconds to enter setting screen.

Function index	
a 1. Circumference and sensing pointsetting	4-1
a 2. RPM pulse setting	4-2
a 3. Fuel gauge resistance setting	4-3
Fuel level manual setting	4-3-1
Fuel level resistance auto detection setting	4-3-2
Fuel warning setting	4-3-3
a 4. Clock setting	4-4
a 5. Backlight brightness setting	4-5
a 6. Oil maintenance mileage setting	4-6
a 7. Speed unit setting	4-7
a 8. External ODO	4-8
a 9. Internal ODO	4-9

4-1 Circumference and sensing pointsetting

- Press the **Select** button to enter the circumference and sensing point setting screen.
- CAUTION!** Please measure the tire circumference (The tire you will install the sensor on) and make sure the number of magnet sensor point (You could install the magnet into the disc screw or the sprocket screw.)
- The speed displayed on the meter will be affected by the setting, please make sure the setting number is correct before you make the setting.
- ⚠ Please reset this setting value when you change a different size tire.**
- Example :** If the tire circumference is 1,300 mm.
- Press the **Select** button to choose the setting number.
- EX.** Now the tire circumference is setting from 1,000 mm.
- ⚠ Now the digit in thousands setting number is flashing!**
- NOTE** Setting range : 300 ~ 2,500 mm
Setting unit : 1 mm
- PS.** You could define the valve as the starting point and the terminal point to measure the wheel circumference with a measuring tape.
- Press the **Adjust** button to choose the setting number.
- EX.** The circumference setting is changed from 1,000 mm to 1,300 mm.
- Example :** If the sensor point is setting 6P.
- Press the **Adjust** button to choose the setting number.
- EX.** Now the sensor point is setting from 1P.
- ⚠ Now the setting value is flashing!**
- NOTE** Sensitive point : 1 ~ 20
- Press the **Select** button to go back to the circumference and sensing point setting screen.
- EX.** Now the sensor point is setting from 1P to 6P.
- Press the **Adjust** button to enter next operation setting.

4-2 RPM pulse setting



- Press the **Select** button to enter the RPM pulse setting screen.



- EX. You want to connect the RPM signal wire to the pick up signal and there are 13 flywheel signals per turn.
- Press the **Adjust** button to choose the setting number.

⚠ Currently setting value will blink.

NOTE Setting range: 0.5 ~ 1 ~ 25

The setting value	The corresponding stroke and pistons number	The corresponding RPM signal number per ignition
0.5	4C-1P	2 RPM signals per 1 ignition.
1	2C-1P 4C-2P	1 RPM signal per 1 ignition.
2	2C-2P 4C-4P	1 RPM signal per 2 ignition.
3	2C-3P 4C-6P	1 RPM signal per 3 ignition.
4	2C-4P 4C-8P	1 RPM signal per 4 ignition.
5	4C-10P	1 RPM signal per 5 ignition.
6	2C-6P 4C-12P	1 RPM signal per 6 ignition.

CAUTION! Most of the 4-cycle bikes with one single piston are igniting every 360 degree once, so the setting should be the same as the bike with 2-cycle and one piston engine.



- Press the **Select** button to enter waveform setting screen.
- EX. Setting engine ignition angle from P-1 to P-13.



- Example : To set waveform to high waveform (Hi-Act).
- Press the **Adjust** button to choose the setting number.

⚠ Currently setting value will blink.

NOTE Setting range : Hi-Act ~ Lo-Act

NOTE During RPM signal detection, if there is any bad sensing or interference, please select another RPM sensing waveform.



- Press the **Select** button to enter rpm stage setting screen.
- EX. Setting from high wave (Hi-Act) to low wave (Lo-Act).



- Example : To set rpm stage value as 10,000 RPM.
- Press the **Select** button to choose the setting number.
- EX. Current rpm stage value is 15,000 RPM.

⚠ Currently setting value will blink.

NOTE Setting range : 10,000 ~ 12,000 ~ 15,000 RPM ~



- Press the **Adjust** button to choose the setting number.



- Press the **Select** button to return to rpm stage setting screen.
- EX. Setting rpm stage value from 15,000 RPM to 10,000 RPM.



- Press the **Adjust** button to enter next operation setting.

4-3 Fuel gauge resistance setting



- Press the **Select** button to enter the circumference and sensing point setting screen.



- Example: If the vehicle is a YAMAHA T-MAX 530, it's resistance is 100 Ω according to the service manual.
- Press the **Adjust** button to choose the setting number.

⚠ Currently setting value will blink.

NOTE The fuel gauge resistance setting range : USER ~ 100 Ω ~ 250 Ω ~ 270 Ω ~ 510 Ω ~ 1200 Ω ~ SW (turn off)



- NOTE** Custom fuel level resistance:
1) Manual - Please check 4-3-1 Fuel Level Resistance Manual Setting Instructions.
2) Auto - Please check 4-3-2 Fuel Level Resistance Auto Setting Instructions.

NOTE Fuel meter will be displayed with the wiring connected.



- Press the **Select** button to enter 4-3-3 fuel warning setting screen.
- EX. Setting fuel meter's resistance value from 100 to 270.

4-3-1 Fuel level manual setting



- Press the **Select** button to enter the lowest fuel level's resistance setting screen.
- Example : For YAMAHA T-MAX 530, according to the service manual, the fuel tank resistance from low to high is 90 - 100 Ω (the lowest) and 4 - 10 Ω (the highest). So enter the setting value as 10 Ω.

P.S.

You could find your fuel level sensor resistance range in the electronic components section in the service manual.

Normally, we will recommend to choose the closest number set as the range to ensure that riders will not run out of gas before the fuel level indication. example, for YAMAHA T-MAX it's 90 - 100 Ω and 4 - 10 Ω, in which case we will suggest to use 90 - 10 Ω as the lowest and highest range.



- Example : To set minimum fuel level as 90 Ω.
 - Press the **Select** button to choose the setting number.
- ⚠ Currently setting value will blink.



- Press the **Adjust** button to choose the setting number.

4-3-2 Fuel level resistance auto detection setting



- Press the **Select** button to enter the lowest fuel level's resistance auto detection screen.
- CAUTION!**
- Before detection, ensure that your current fuel level is in the lowest position that you would like to have.
 - Stop the vehicle for a few seconds to allow the fuel surface to become steady, then start the detection of the resistance.

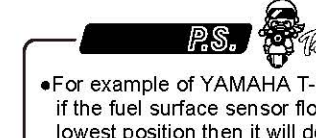

- For example of YAMAHA T-MAX 530, if the fuel surface sensor float in the lowest position then it will detect the resistance around 90 Ω.

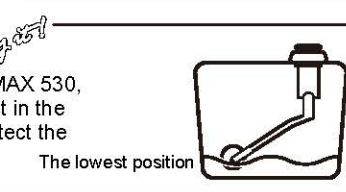

- Press the **Adjust** button to detect the lowest fuel level's resistance.



- Press the **Select** button 5 times to enter the lowest fuel level resistance auto detection screen.
- EX. Auto Detection the lowest fuel level resistance is 90 Ω.



- Press the **Select** button twice to enter maximum fuel resistance value setting screen.
- EX : Setting minimum fuel level from 0 to 90.



- Example : To set maximum fuel level as 10.
 - Press the **Select** button to choose the setting number.
- ⚠ Currently setting value will blink.



- Press the **Adjust** button to choose the setting number.



- Press the **Select** button twice to enter 4-3-3 fuel warning setting menu.
- EX. The highest fuel level setting is changed from 0 to 10 Ω.



- Press the **Select** button twice to enter 4-3-3 fuel warning setting menu.
- EX. The highest fuel level setting is changed from 0 to 10 Ω.



- Press the **Select** button twice to enter 4-3-3 fuel warning setting menu.
- EX. The highest fuel level setting is changed from 0 to 10 Ω.



- Press the **Select** button twice to enter 4-3-3 fuel warning setting menu.
- EX. The highest fuel level setting is changed from 0 to 10 Ω.

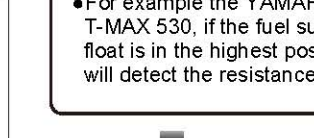

- Press the **Select** button twice to enter 4-3-3 fuel warning setting menu.
- EX. The highest fuel level setting is changed from 0 to 10 Ω.



- Press the **Adjust** button to detect the highest fuel level resistance.



- Press the **Select** button 5 times to go back to the fuel gauge resistance.
- EX. Automatically detect the highest fuel level resistance value as 10 Ω.

4-3-3 Fuel warning setting



- Example : To set fuel warning value as 30%.
- Press the Adjust button to choose the setting number.
- ⚠ Currently setting value will blink.
- NOTE** Setting range : 10%, 20%, 30%, 40%, 50%.
Fuel meter will not display when fuel meter's wire is not installed.



- Press the Adjust button to enter next operation setting.

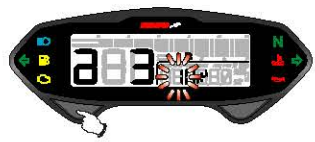

- Press the Select button to return to fuel level resistance value setting screen.
- EX. Setting maximum fuel level from 30% to 10%.

4-4 Clock setting



- Press the Select button to enter the clock setting screen.



- Example : To set time (minute) as 10 minutes.
- Press the Select button to choose the setting number.
- ⚠ Now the setting value is flashing!
- NOTE** Setting range : 00 ~ 59 minutes.



- Example : Changing the 24H.
- Press the Adjust button to choose the setting number.
- ⚠ Currently setting value will blink.
- NOTE** Setting range: 12 / 24 H



- Press the Adjust button to choose the setting number.



- Press the Select button to enter time adjustment (hour / minute) setting screen.
- EX. Setting time format from 12-hours to 24-hours.



- Press the Select button to return to time setting screen.
- EX. Setting hour/minute from 0 hour 0 minute to 10 hours 10 minutes.



- Example : To set time(hour) as 10 hours.
- Press the Adjust button to choose the setting number.
- ⚠ Currently setting value will blink.
- NOTE** Cursor moving order is : Hour > Digit in ten minutes > Digit in minutes
- NOTE** Setting range : 0 ~ 23



- Press the Adjust button to enter next operation setting.

4-5 Backlight brightness setting



- Press the Select button to enter the backlight brightness setting screen.



- Press the Select button to go back to the backlight brightness setting screen.
- EX. The backlight brightness setting is changed from 5 (100%) to 3 (60%).



- Example : You want to set the brightness at 60 % (3).
- Press the Adjust button to choose the setting number.
- ⚠ Currently setting value will blink.
- NOTE** Setting range : 1 (Darkest) ~ 5 (Brightest), 5 different levels available.
Setting unit : 20% per level.
The backlight brightness will change immediately after you set the value.



- Press the Adjust button to enter next operation setting.

4-6 Oil maintenance mileage setting



- Press the Select button to enter the oil maintenance mileage setting screen.

- ⚠ Currently setting value will blink.
- NOTE** ●2-stroke motor oil mileage is indicated by external signal warning (motor oil indicator will lit).
- 4-stroke motor oil mileage is internally set by the chronograph.



- Example : To set motor oil mileage value as 4T.
- Press the Adjust button to choose the setting number.
- EX. Current motor oil mileage is 2T.
- ⚠ Currently setting value will blink.
- NOTE** Setting range : 2T / 4T



- Press the Adjust button to choose the setting number.



- Press the Select button to enter 4T motor oil mileage setting main screen.
- EX. Setting motor oil mileage value from 2T to 4T.



- Press the Select button to go back oil maintenance mileage setting screen.
- EX. Setting motor oil mileage parameter from 1,000 to 1,500.



- Example : To set motor oil mileage parameter as 1,500.
- Press the Select button to choose the setting number.
- EX. Current motor oil mileage parameter is 1,000.



- Press the Adjust button to enter next operation setting.

4-7 Speed unit setting



- Press the Select button to enter the speed unit setting screen.



- Press the Select button to go back speed unit setting screen.
- EX. The speed unit setting is changed km/h - km to MPH - mlie.



- Press the Adjust button to choose the setting number.



- Press the Adjust button to enter next operation setting.

4-8 External ODO



- Press the Select button to enter the external ODO setting screen.



- Press the Select button to the external ODO setting screen.
- EX. The external ODO is changed 0 to 12,500 km.



- Example : To set external total mileage value to 12,500 km.
- Press the Select button to choose the setting number.
- ⚠ Currently setting value will blink.
- NOTE** Setting range : 0 ~ 99,999 km (mile)



- Press the Adjust button to enter next operation setting.



- Press the Adjust button to choose the setting number.

4-9 Internal ODO



- Example : Current internal ODO is 50,000 km.
- Press the **Select** button three seconds to go back to ODO screen.

⚠ User unable to adjust and clear internal ODO.

NOTE Setting range : 99999.9 km (mlie).



- The main screen.

5 Trouble shooting

The following situation do not indicate malfunction of the meter. Please check the following before taking it in for repair.

Trouble	Check item	Trouble	Check item
The meter doesn't work when the power is on.	<ul style="list-style-type: none"> ● The power doesn't supply to the meter. →Please make sure the wiring is connected. ● The wiring and fuse are not broken. →The battery is broken or the battery is too old to supply enough power (DC 8 V) to make the meter work. 	Tachometer does not appear or appear incorrectly	<ul style="list-style-type: none"> ● Please check the RPM sensor wiring is connected correctly. ● Please check the spark plug is R type or not. If not, please replace the spark plug with the R type spark plug. ● Please check your setting. →Please refer to the manual 4-2 RPM pulse setting.
The meter shows wrong information.	<ul style="list-style-type: none"> ● Check the voltage of your battery, and make sure the voltage is over DC 8 V. 	The odometer and trip meter is not accumulated or accumulated wrong data.	<ul style="list-style-type: none"> ● It is possible that the permanent power wire is not connected well. →Please check the red positive wire is connect well or not.
Speed does not appear or appear incorrectly.	<ul style="list-style-type: none"> ● Make sure the speed sensor is connected properly. →Please check if speed sensor is connected and working properly. Also check whether the cable of speed sensor has broken or lose or not. ● Check the tire-size setting. →Refer to the manual 4-1 circumference and sensing point setting. 	Fuel gauge does not appear or appear incorrectly.	<ul style="list-style-type: none"> ● Check your fuel tank. ● Check the wiring harness. →Is the wire connected properly. ● Check the tire-size setting. →Refer to the manual 4-3 fuel gauge resistance setting.
The odometer and trip meter are not accumulated or accumulated the wrong data.	<ul style="list-style-type: none"> ● It is possible that the permanent power wire is not connected properly. →Check if the red positive wire is connect properly. 		

* If the problem is not resolved after following the steps shown above, please contact your local distributor for assistance.