

# INSTALLATION



Thank you for purchasing our DB-03R meter, before operating this unit, please read carefully the instruction sheet and retain it for future reference.

## Notice

1. This meter work on DC 12 volts applications only.
2. For proper installation, please follow the steps described in the instruction. Any damages caused by wrong installation shall be imputed to the users.
3. Don't break or modify the wire terminals. To avoid any short circuit, do not pull the wires out of the terminal when installing.
4. Do not disassemble or change any parts.
5. Opening the instrument will void any warranty. Maintenance or repair should be executed by our professionals only.

### MARK MEANING:

Some procedures must be followed to avoid damages to the instrument.

**WARNING!** Some procedures must be followed to avoid injuries to the user or others.

**CAUTION!** Some procedures must be followed to avoid damages to the vehicle.

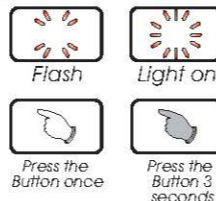

## 1-1 Accessory

<b>1</b> LCD meter X 1	<b>2</b> Main wiring harness X 1	<b>3</b> RPM WIRE (TYPE A) X 1	<b>4</b> RPM WIRE (TYPE B) X 1
<b>5</b> Temp sensor wire set X 1	<b>6</b> PT 1/8 water temp sensor X 1	<b>7</b> Speed sensor X 1	<b>8</b> D6 X 5L mm magnet X 6
<b>9</b> M8/ S type speed sensor bracket X 1	<b>10</b> M10/ S type speed sensor bracket X 1	<b>11</b> M5X5L Hexagon screw X 2	<b>12</b> 2.5 mm Allen Key X 1
<b>13</b> 4 mm Allen Key X 1	<b>14</b> Meter bracket X 1	<b>15</b> M5 washer X 2	<b>16</b> M4 X 10L screw X 2
<b>17</b> Mid-way connector X 10	<b>18</b> M5 x 12L screw X 2	<b>19</b> Bracket X 1	

**NOTE** Please contact your local distributor if the items received in the box are not the same as the one listed above.

## 1-2 Optional accessories

<b>1</b> Active speed sensor	<b>2</b> Disc magnet screw 5/16-18 X 22.1L M5 X P0.8 X 12L M6 X P1.0 X 12.6L M6 X P1.0 X 19.7L M6 X P1.0 X 24L M8 X P1.25 X 22.5L M8 X P1.25 X 27.5L M8 X P1.25 X 29L M10 X P1.25 X 28.3L	<b>3</b> L TYPE speed sensor bracket	<b>4</b> Oil temp sensor adapter M12 X P1.5 X 15L M14 X P1.25 X 15L M14 X P1.5 X 15L M16 X P1.5 X 15L M18 X P1.5 X 15L M20 X P1.0 X 15L M20 X P1.5 X 15L
<b>5</b> Water temp sensor adapter M14 M16.M18 M22.M26 mm	<b>6</b> Temp sensor M10 X P1.0 M12 X P1.5 M14 X P1.25 M14 X P1.5 M16 X P1.5 / M18 X P1.5	<b>7</b> Temp sensor wire set (2 M)	

**NOTE** The optional active speed sensor can read up to 60 pulses and do not require the installation of any magnets to pick up the speed signal. Note that the passive speed sensor supplied with the instrument can read up to 6 pulses.

**NOTE** Some of the optional accessories might not be available in your country. Contact your local distributor to get more details.

## 2-1 Wiring installation instructions

**Main power switch wire reference:**

	Power	Key on	Ground
YAMAHA	Red	Brown	Black
HONDA	Red	Red / Black	Green
SUZUKI		Black	Green
KAWASAKI	White	Brown	Black / Yellow
KYMCO	Red	Black	Green
SYM	Red	Black	Green
PGO	Red / White	Orange	Black

**NOTE** The color listed above may differ depending on the model and year.

**RPM wire reference:**

	YAMAHA	HONDA	SUZUKI	KAWASAKI	APRILIA	BMW	BENELLI	BUELL	CAGIVA	DUCATI	H.D	MV	TRIUMPH
	Yellow / Black	Yellow / Green	Yellow / Blue	Light Blue	Gray / Violet	Black	Gray / Violet	Pink	Gray / Green	Gray / Green	Pink	Gray / Yellow	Red

**NOTE** The color listed above may differ depending on the model and year.

**Fuel indicator wire reference:**

	YAMAHA	HONDA	SUZUKI	KAWASAKI	KYMCO	SYM	PGO
	Green	Yellow / White	Yellow / White	Black / L Green	Yellow / White	Yellow / White	Gray

**NOTE** The fuel sensor is electronic type, do not connect in parallel with the original wire - otherwise the fuel gauge won't display. The wrong installation of the fuel wire might damage the instrument.

**NOTE** The temperature reading will disappear on the screen if the temperature sensor is not connected to the meter.

**NOTE** When connecting the power wire, please follow carefully the instruction. If the red & brown wires are connected in parallel, the meter won't work properly.

**The RPM wire installation**

- Wrap the RPM wire at least 5 times around the spark plug wire.
- Use adhesive tape to attach the RPM wire (Type A) onto the spark plug wire.
- Use adhesive tape to attach the RPM wire (Type A) on the spark plug cap.
- Use adhesive tape to attach the RPM wire (Type A) on the coil positive pole wire. For some models with the coil negative wire, please tape the RPM wire (Type A) on the negative wire to get the RPM signal. (For example, the YAMAHA V-max 1200)
- Connect the RPM wire (Type B) on the spark plug wire by connecting the male and female connectors.
- Wrap the RPM wire (Type B) on the spark plug wire by connecting the male and female connector.
- Connect the RPM wire (Type A) to the pick up sensor.
- Connect in parallel the RPM wire (Type A) with the original tachometer signal wire (This method is available only when the original speedometer comes with a tachometer on it. You could get the proper RPM wire information from the service manual of your bikes.)
- For the applications with the new model of ignition coil, please wrap the RPM wire (Type A) at least 5 times around the spark plug as shown on the above drawing.
- Use the method mentioned above to install the RPM wire, and then connect the ground wire to the bike body or the engine (must be a good ground).

**For multi-ignition models, we will suggest you to get the signal on the first ignition. The best signal source will be in order as D>C>B>A, we will suggest you to check different ways if you have problems to get the RPM signal.**

## 2-2 Installation instruction.

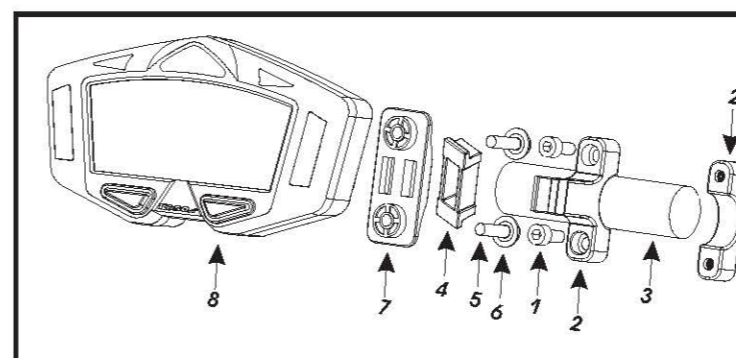

When installing, please follow the steps below.

1. M5 x 12L screw x2
2. Meter bracket for handle bar
3. Fix the bracket on handle bar (7/8 inch)
4. Bracket x1
5. M4 x 10L screw x2
6. M5 washer x2
7. Meter board
8. Attach the meter on the board with the screws.
9. Attach the meter and the bracket together.

**NOTE** Adjust the meter to the proper angle before tightening the handle bar bracket screws.

## 2-3 Installation instruction

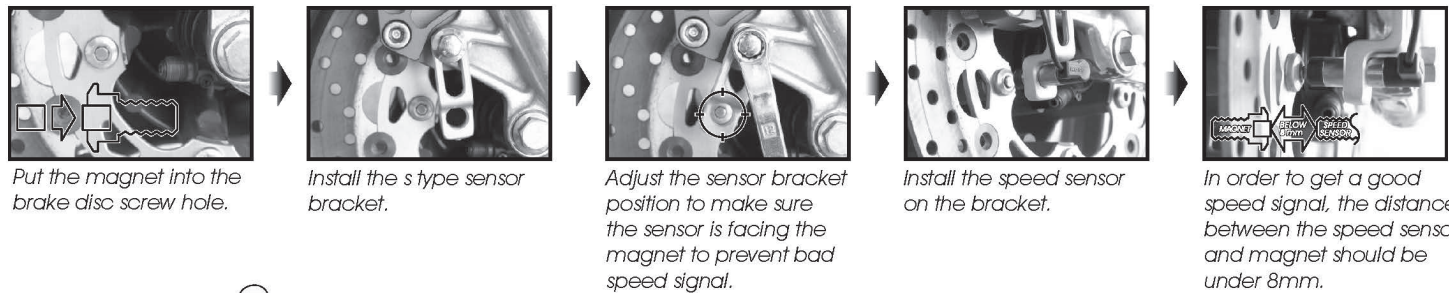

Put the magnet into the brake disc screw hole.

Install the S-type sensor bracket.

Adjust the sensor bracket position to make sure the sensor is facing the magnet to prevent bad speed signal.

Install the speed sensor on the bracket.

In order to get a good speed signal, the distance between the speed sensor and magnet should be under 8mm.



Higher number of magnets installed on the disk brake will result in a faster speed display on the gauge. The letter "N" on the magnets must face the speed sensor in order to pick up correctly the speed.

EX 1: If the disk brake has 3 screws, you can install 1 or 3 magnets.  
EX 2: If the disk brake has 4 screws, you can install 1, 2 or 3 magnets.  
EX 3: If the disk brake has 5 screws, you can install 1 or 5 magnets.  
EX 4: If the disk brake has 6 screws, you can install 1, 2, 3 or 6 magnets.

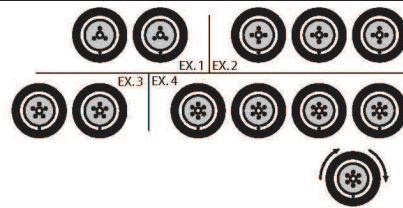

## 3-1 Basic function instruction

**Tachometer**

- Display range: 0~10,000 / 0~12,000 / 0~15,000 RPM.
- Display unit: 10,000 RPM-Each level represents 166 RPM, 12,000 RPM-Each level represents 200 RPM, 15,000 RPM-Each level represents 250 RPM

**Temperature warning**

- Setting range: 60~250°C (140~482°F)
- Setting unit: 1°C (°F)

**Speeding warning**

- Setting range: 30~360 km/h (19~225 MPH)
- Setting unit: 1 Km/h (MPH)

**Thermometer**

- Display range: 0.0~250.0°C (32.0~482.0°F)
- Display unit: 0.1°C (°F)
- Display: -----°C (-----°F) if temperature sensor is not connected.

**Digital Volt meter**

- Display range: DC 8~DC 18 V
- Flashing warning when Voltage lower than 11.5 V or higher than 15.5 v.

**Clock**

- 24H

**The RPM Red, Yellow shift light**

- Setting range: 1,000~15,000 RPM
- Setting unit: 100 RPM
- Warning: Light on (F-OFF), Flash (F-ON)

**Speedometer**

- Display range: 0~360 km/h (0~225 MPH)
- Display unit: km/h (MPH) for alternative

**Odometer**

- Display range: 0~99999 km (mile), reset automatically after 99999 km.
- Display unit: 1 km (mile).

**Trip meter A.B**

- Display range: 0~999.9 km (mile), reset automatically after 999.9 km.
- Display unit: 0.1 km (mile).

**Total hour meter**

- Display range: 0~99999 H.
- Display unit: 1 H.

**Hour meter A.B**

- Display range: 0.0~999.9 H.
- Display unit: 0.1 H.

**MAX record**

The meter will record the top speed, RPM, gear and temperature automatically.

**Fuel Level**

- Display range: 6 levels.
- The fuel level begins to flash when only 1 level is left.

**Gear meter**

- Display range: N, 1, 2, 3, 4, 5, 6, 7, 8, 9

## 3-2 Functions

● Speedometer	Display range: 0~360 km/h (0~225 MPH) Display unit: km/h or MPH	○ The RPM input signal number setting	Setting range: 0.5, 1~24
○ Display internal	<0.5 second	○ The RPM input pulse	Setting range: HI (The positive wave pulse) Lo (The negative wave pulse)
○ Odometer	Display range: 0~99999 km (mile), reset automatically after 99999 km (mile).	● Temperature unit	Display unit: °C & °F
○ Trip meter A/B	Display range: 0~999.9 km (mile), reset automatically after 999.9 km (mile). Display unit: 0.1 km (mile).	● Thermometer	Display range: 0.0~250.0°C (32.0~482.0°F) Display unit: 0.1°C (°F)
● Speeding warning	Display range: 30~360 km/h (19~225 MPH) Display unit: 1 km/h (MPH)	○ Display internal	<0.5 second
● Total hour meter	Display range: 0~99999 H. Display unit: 1 H.	○ Over temp warning (Water temperature)	Setting range: 60~250°C (140~482°F) Setting unit: 1°C (°F)
● Hour meter A.B	Display range: 0.0~999.9 H. Display unit: 0.1 H.	○ Top temperature record	Display range: 0~250°C (32~482°F)
○ Tire circumference	Setting range: 300~2,500 mm Setting unit: 1 mm, Sensitive point: 1~20	● Gear meter	Display range: N, 1, 2, 3, 4, 5, 6, 7, 8, 9
● Tachometer	Display range: 0~10,000 / 0~12,000 / 0~15,000 RPM. Display unit: 10,000 RPM-Each level represents 166 RPM, 12,000 RPM-Each level represents 200 RPM, 15,000 RPM-Each level represents 250 RPM	● Fuel meter	Display range: 6 levels Display unit: Each level represents 16.6 % Setting range: 100Ω, 250Ω, 510Ω, 1200Ω, SW
○ Display internal	<0.5 second	● Clock	24 H
○ The RPM Red, Yellow shift light	Setting range: 1,000~15,000 RPM Setting unit: 100 RPM	● Volt meter	Display range: DC 8~18 V. Flashing warning when Voltage lower than 11.5 V or higher than 15.5 v.
○ Warning	Light on (F-OFF) Flash (F-ON)	● Backlight brightness light	Setting range: 1-5 (Darkest)~5-5 (Brightest) Display unit: Each level represents 20 %
○ MAX RPM record	Display range: 0~10,000 / 0~12,000 / 0~15,000 RPM	● Backlight color	Setting range: blue, orange, purple
		● Effective voltage	DC 12V
		● Effective temperature range	-10~+60°C
		● Meter standard	JIS D 0203 S2
		● Meter size	120 X 68.5 X 44.1 mm
		● Meter weight	Around 127.3 g
		● Indicator light color	Neutral-green, High beam-blue, Repeater-green, EOBD-amber, Oil-red, Temperature alarm-red, Speeding warning-red, RPM shift light (Red, Yellow)

**NOTE** Design and specifications are subject to change without notice!

## 3-3 Button function instruction

### Press the Left button

1. In main screen, press the Left button to choose the clock, volt, water temperature or MAX record display.
2. In setting screen, press the Left button to choose the function you want to set.
3. When the meter is off, press the Left button to wake up the clock.

### Hold the Left button for 3 seconds

1. In setting screen, hold pressing the Left button for 3 seconds to go back to the main screen.

### Press the Right button

1. In main screen, press the Right button to choose the odometer, trip A, trip B, total hour meter, hour meter A or hour meter B display.
2. In setting screen, press the Right button to change the setting numbers. If you keep pressing down the Right button the number will increase quickly.
3. When the meter is off, press the Right button to wake up the clock.

### Hold pressing the Right button for 3 seconds

1. In the main screen, hold the Right button for 3 seconds to reset the trip A, trip B, hour meter A, hour meter B and the MAX record.

### Hold the Right button

1. In the setting screen, hold the right button to add quickly the set value.

### Hold pressing the Right+Left for 3 seconds

1. In main screen, hold the Right+Left buttons at the same time for 3 seconds to enter the setting screen.

## 3-4 Stand by function instruction



● When the meter is off, press **Right or Left button** to wake up the clock.



● The clock will display 30 seconds after wake up.

### 3-5 Main function instruction (Right button)



● In main screen (ODO), Press the **Right button** one time to enter the Trip A screen.



● In Trip A screen, Press the **Right button** one time to enter the trip B screen.

● Hold the **Right button** for 3 seconds to reset Trip A.



● In Trip B screen, Press the **Right button** one time to enter the total hour meter screen.

● Hold **Right button** for 3 seconds to reset Trip B.



● In the total hour meter screen, Press the **Right button** one time to enter the hour meter A screen.



● In the hour meter A screen, Press the **Right button** one time to enter the hour meter B screen.

● Hold the **Right button** for 3 seconds to reset hour meter A record.



● In hour meter B screen, Press the **Right button** one time to go back to the main screen.

● Hold the **Right button** for 3 seconds to reset hour meter B record.



### 3-6 Main function switch instruction (Left button)



● In the clock screen, press the **Left Button** one time to enter the volt screen.



● In the volt screen, press the **Left Button** one time to enter the water temperature screen.



● In the water temperature screen, press the **Left Button** one time to enter the MAX record screen.



● In the MAX record screen, press the **Left Button** one time to go back to the clock screen.

### 3-7 Setting screen instruction



1.Speed and Temp. Unit



2.Speeding warning setting

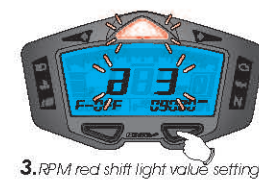

3.RPM red shift light value setting and flashing ON/OFF

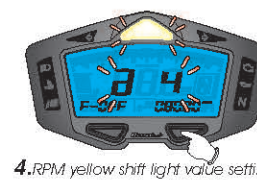

4.RPM yellow shift light value setting and flashing ON/OFF



5.Temperature warning setting



6.Circumference and sensing point



7.Signal type and piston numbers

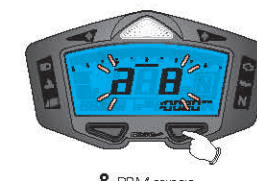

8.RPM range



9.Fuel gauge resistance



10.Clock



11.Backlight colors and brightness



12.Gear meter



13.Internal ODO display



14.External ODO setting

▲ The screen will return to the main screen after 30 seconds if no button is press.

### 4 Entering setting screen



● In the main screen, hold for 3 seconds the **Left & Right button** to enter the setting screen.

#### 4-1 Unit setting (Speed, Temperature)

● Press the **Left button** one time to enter the speed unit setting screen.

▲ Now, a1 is flashing on the screen!



● EX. To change the setting from MPH to km/h.

● Press the **Right button** to change the setting.

▲ The odometer & trip meter value will change according to the speed unit.



● Press the **Left button** one time to enter the temperature setting screen.



● EX. To change the setting from °C to °F.

● Press the **Right button** to change the setting.

▲ The temperature unit is now flashing!



● Press the **Left button** once to go back to the a1 screen.

● EX. The temperature unit setting is changed from °C to °F.



● Press the **Right button** once to enter the speeding warning setting screen.

▲ Now the a1 is flashing!



#### 4-2 Speeding warning setting

● Press the **Left button** once to enter the speeding warning setting screen.

▲ Now the a2 is flashing!



● EX. We want to change the setting to 80 km/h.

● Press the **Left button** to move to the digit you want to set.

● Press the **Right button** to change the setting.

Note Setting range: 30~360 km/h (19~225 MPH)  
Setting unit: 1 Km/h (MPH)



▲ The setting unit will change together will the speed unit setting (4-1).



● Press the **Left button** once to go back to the a2 screen.

● EX. Now the setting is changed from 60 km/h to 80 km/h.



● Press the **Right button** once to enter the red shift light setting screen.

▲ Now the a2 is flashing!



#### 4-3 Red shift light setting

● EX. Set the red shift light at 9,500 RPM.

● Press the **Left button** to move to the digit you want to set.

● Press the **Right button** to change the value.

Note Setting range: 100~15,000 RPM  
Setting unit: 100 RPM

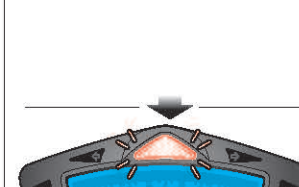

● Press the **Left button** one time to enter the red shift light warning setting screen.

● EX. The red shift light is set from 9,000 RPM to 9,500 RPM.

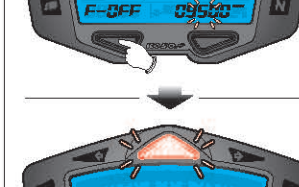

● EX. To set F-ON (Flashing ON) red shift light warning.

● Press the **Right button** to change the setting value.

Note Light on Flash



● Press the **Left button** one time to go back to the a3 screen.

● EX. The red shift light warning is set form F-OFF to F-ON.



● Press the **Right button** once to enter the yellow shift light setting screen.

▲ Now, a3 is flashing on the screen!



#### 4-4 Yellow shift light setting

● EX. Set the yellow shift light at 8,500 RPM.

● Press the **Left button** to move to the digit you want to set.

● Press the **Right button** to change the setting.

Note Setting range: 100~15,000 RPM  
Setting unit: 100 RPM



Note Setting range: 100~15,000 RPM  
Setting unit: 100 RPM



- Press the **Left button** once to enter the yellow shift light warning setting screen.
- EX. The yellow shift light as been set from 8,000 RPM to 8,500 RPM.



- EX. To set F-ON (Flashing ON) for Yellow shift light warning.
- Press the **Right button** to change the setting value.



- Press the **Left button** once to go back to the a4 screen.
- EX. The yellow shift light warning as been set form F-OFF to F-ON.

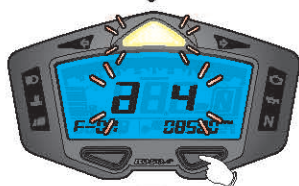

- Press the **Right button** once to enter the over temp warning (Water temperature) setting screen.

▲ Now, a4 is flashing on the screen!



PS. If you set the RPM yellow shift light at 8,500 RPM, the red shift light will light on at 9,500.



- #### 4-5 Over temp warning setting (Water temperature)
- EX. Set the over temp warning value at 105°C.

- Press the **Left button** to move to the digit you want to set.



- Press the **Right button** to change the value.



Note Setting range: 60~250°C (140~482°F)  
Setting unit: 1°C (°F)



- Press the **Left button** once to go back to the a5 screen.
- EX. Now the over temp warning (water temperature) as been set form 100°C to 105°C.



- Press the **Right button** once to enter the tire circumference and sensor point setting screen.
- ▲ Now, a5 is flashing on the screen!

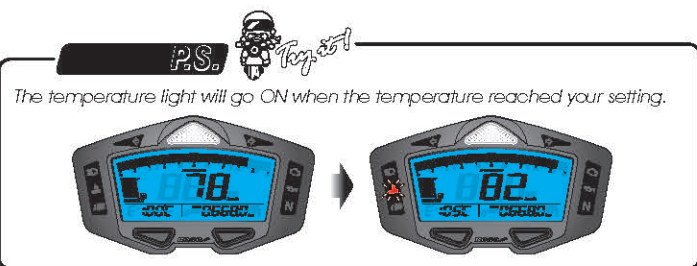

The temperature light will go ON when the temperature reached your setting.



#### 4-6 Tire circumference and sensor point setting

- EX. If the tire circumference is at 1,300 mm.

- Press the **Left button** once to enter the tire circumference setting screen.
- Press the **Left button** to move to the digit you want to set.



- Press the **Right button** to change the value.



Note Setting range: 300~2500.  
Setting unit: 1mm

#### CAUTION!

- Measure the circumference of tire which the sensor will be installed and keep note of the number of sensor points.

- The speed displayed on the meter will be affected by the setting. Make sure the tire size and the number of sensor point is correct before you set the value.



- EX. If the sensor point is set at 06P.
- Press the **Left button** once to enter the sensor point setting screen.
- Press the **Left button** to move to the digit you want to set.



- Press the **Right button** to change the value.



Note Setting range: 01P~20P.  
Setting unit: 01P.

- EX. Now the tire circumference is set from 1,000 to 1,300 mm.



- Press the **Left button** once to go back to the a6 screen.
- EX. The sensor point is now set from 01P to 06P.



- Press the **Right button** once to enter the input pulse setting screen.
- ▲ Now, a6 is flashing on the screen!



#### 4-7 RPM input signal setting

- EX. You want to connect the RPM signal wire to the pick up signal and there are 13 flywheel signals per turn.
- Press the **Left button** once to enter the RPM input signal setting screen.
- Press the **Right button** to change the value.



Note Setting range: 0.5, 1~24.

setting value	2 strokes setting	4 strokes setting	RPM per spark
0.5		1 piston	2 RPM signals per 1 spark.
1	1 piston	2 pistons	1 RPM signal per 1 spark.
2	2 pistons	4 pistons	1 RPM signal per 2 sparks.
3	3 pistons	6 pistons	1 RPM signal per 3 sparks.
4	4 pistons	8 pistons	1 RPM signal per 4 sparks.
5	5 pistons	10 pistons	2 RPM signals per 10 sparks.
6	6 pistons	12 pistons	1 RPM signal per 6 sparks.

Note For most of Injection Model, setting value might exceed 6 if RPM connection method B is chosen, and it depend on the number of the bump it has on its flywheel.

CAUTION! Some of the 4 strokes engine with 1 piston are igniting once every 360 degree. To get the proper RPM for such engines, the setting should be the same as a 2 strokes engine with 1 piston.

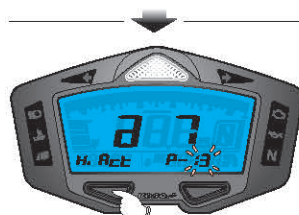

- EX. Change the setting to Lo.
- Press the **Left button** once to enter the input pulse setting screen.
- Press the **Right button** to change the value.

Note We define the RPM input pulse as Hi (The positive pulse) & Lo (The negative pulse.)

Note If the RPM displayed on the meter is incorrect, choose another setting and try it again.



- Press the **Left button** once to go back to the a7 screen.
- EX. The input pulse setting as been changed from Hi to Lo.



- Press the **Right button** once to enter the RPM range setting screen.
- ▲ Now, a7 is flashing on the screen!

#### 4-8 RPM setting range

- EX. Set the RPM range is at 15000 RPM.
- Press the **Left button** once to enter the RPM range setting screen.
- Press the **Right button** to change the value.



Note Setting range: 0~10,000 RPM, or 0~12,000 RPM, or 0~15,000 RPM



- Press the **Left button** once to go back to the a8 screen.
- EX. Now the RPM range has been changed from 10,000 to 15,000 RPM.



- Press the **Right button** once to enter the fuel resistance setting screen.
- ▲ Now, a8 is flashing on the screen!



#### 4-9 Fuel gauge resistance setting

- EX. The fuel gauge need to be set to 5100Ω.
- Press the **Left button** once to enter the fuel resistance setting screen.
- Press the **Right button** to change the value.



Note The fuel gauge resistance setting range: 100Ω, 250Ω, 510Ω, 1200Ω, SW (turn off).

Note When Fuel Setting is set to "SW", the fuel level symbol will light up when fuel level signal wire is connected to the negative (-) wire.

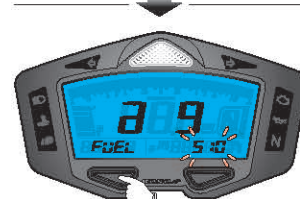

- Press the **Left button** once to go back to the a9 screen.
- EX. The setting has been changed from 100Ω to 5100Ω.



- Press the **Right button** once to enter the clock setting screen.

▲ Now, a9 is flashing on the screen!



#### 4-10 clock setting

- EX. Set the clock at 0:05.
- Press the **Left button** once to enter the clock setting screen.
- Press the **Left button** to move to the digit you want to set.



- Press the **Right button** to change the value.



Note This is a 24 H clock.



- Press the **Left button** once to go back to the a10 screen.
- EX. The clock has been set from 0:00 to 0:05.



- Press the **Right button** once to enter the backlight brightness and color setting screen.
- ▲ Now, a10 is flashing on the screen!



#### 4-11 Backlight brightness & color setting

- Press the **Left button** once to enter the backlight color setting screen.
- Press the **Right button** to change the value.



**Note** Color setting screen:  
C-b(Blue) · C-Or(Orange) · C-Pu(Purple) °



- **EX. Change the backlight brightness to 3-5 (60% brightness.)**
- Press the **Left button** once to enter the backlight brightness setting screen.
- Press the **Right button** to change the value.



**Note** Setting range: 1-5 (Darkest) ~ 5-5 (Brightest), 5 different levels available.  
Setting unit: 20% per level.  
**The backlight brightness will change immediately after you set the value.**



- Press the **Left button** once to go back to the a11 screen.
- **EX.** The backlight brightness has been set from 5-5 to 3-5.



- Press the **Right button** once to enter the gear learning setting screen.
- ⚠ **Now, a11 is flashing on the screen!**



#### 4-12 Gear learning setting

⚠ If any changing happen for tires circumference or sensing point (4-6), the RPM input signal (4-7), then the gear indicator need to re-learn the gear positioning.

- Press the left button once to choose turn on or off the gear indicator display.
- Press right button to choose the setting mode.



- Press the **Left button** once, the LEARN is flashing!



- Hold pressing the **Right button for 3 seconds** to enter the gear learning setting screen.

**Note** If you don't want the meter to learn the gear position, then press right button once to enter the odometer display screen. (see 4-13)



- Start the riding when "GO" is flashing.

**Note** Press and hold the right button for 3 seconds to quit the learning and return to the previous screen.



#### STEP 1



- When the number 1 is flashing. Put the motorcycle in 1st gear and start riding slowly the motorcycle until the meter detect the correct gear. Once the meter has detected the 1st gear, the screen will automatically switch to number 2.

#### STEP 2



- When the number 2 is flashing. Put the motorcycle in 2nd gear and start riding slowly the motorcycle until the meter detect the correct gear. Once the meter has detected the 2nd gear, the screen will automatically switch to number 3.

#### STEP 3



- When the number 3 is flashing. Put the motorcycle in 3rd gear and start riding slowly the motorcycle until the meter detect the correct gear. Once the meter has detected the 3rd gear, the screen will automatically switch to number 4.

#### STEP 4



- **EX:** The main screen now display the number 6. If your motorcycle have 7 gears, slow down and wait until the meter goes back to the main screen.



#### 4-13 Odometer display

- Press the **Right button** once to enter the odometer setting screen.
- **EX.** The odometer display is 12500 km.



#### 4-14 Odometer setting

- **EX. Set the odometer to 15000 km.**
- Press the **Left button** once to enter the external odometer setting screen.
- Press the **Left button** to move to the digit you want to set.
- Press the **Right button** to change the value.



- Press the **Left button** once to go back to the a14 screen.
- **EX.** The odometer setting has been changed from 7750 to 15000 km.



- Press the **Right button** once to go back to the main screen.

⚠ **Now, a14 is flashing on the screen!**



- Main screen.

## 5 Fuel gauge resistance reference

YAMAHA	JOG 50,100	100Ω	KYMCO	GOING 100	510Ω	
	RS 100	100Ω		JR 100	510Ω	
	RSZ 100	100Ω		SR G4 125	510Ω	
	SV MAX 125	100Ω		V-LINK GP 125	510Ω	
	Cygnus 125	100Ω		KTR 150	100Ω	
	New Cygnus 125	100Ω		RACING 125,150	1200Ω	
	GTR 125	100Ω		QUANNON 150	1200Ω	
	LC 135	100Ω		G5 125,150	1200Ω	
	NEW LC 135	100Ω		G6 150	100Ω	
	LAGENDA 110	100Ω		VJR 50, 110	1200Ω	
	S-MAX 150	100Ω		SYM	S-PRO 100	100Ω
	T-MAX 530	100Ω			Wolf 125	100Ω
	MIO 110	100Ω		PGO	G-MAX 125	100Ω
	AEROX 50	100Ω			X-HOT 125,150	100Ω
	BWS 125	100Ω			I'ME 125	100Ω
HONDA	MSX 125	270Ω	J BUBU 115		700Ω	
	WAVE 110	510Ω	AF 125,150		700Ω	
	GN5 110	510Ω	G-MAX 150	700Ω		
	SH-150i	510Ω	AEON	Elite 250	100Ω	
	PCX 125	100Ω		CO-IN 125	100Ω	
CBR 250	180Ω	MY 125,150		100Ω		
GILERA	RUNNER 50	100Ω	OZ 125,150	100Ω		
PEUGEOT	SpeedFight 50	100Ω	Hartford	Mini 125	100Ω	
APRILIA	SR 50	100Ω		HD 150	100Ω	
SUZUKI	V125	100Ω				

## 6 Trouble shooting

The following situation do not indicate malfunction of the meter.  
Please check the following before taking it in for repair.

Trouble	Check item
The meter doesn't work when the power is on.	<ul style="list-style-type: none"> <li>●The power is not supplied properly to the meter.</li> <li>→Make sure the wiring harness is connected correctly. The wiring and fuse might be broken.</li> <li>→The battery is too old to supply enough <b>DC 12V</b> power to make the meter work.</li> </ul>
The meter shows wrong information.	<ul style="list-style-type: none"> <li>●Check the voltage of your battery, and make sure the voltage is over <b>DC 12V</b>.</li> </ul>
Speed does not appear or appear incorrectly.	<ul style="list-style-type: none"> <li>●Make sure the speed sensor is connected properly.</li> <li>●Check the tire-size setting.</li> <li>→Refer to the manual 4-6.</li> </ul>
Tachometer does not appear or appear incorrectly.	<ul style="list-style-type: none"> <li>●Check the RPM wire is connected correctly.</li> <li>●Check if the spark plug is a "R" type. If not, replace the spark plug with the "R" type spark plug.</li> <li>●Check your setting.</li> <li>→Please refer to the manual 4-7.</li> </ul>
Temp does not appear or appear incorrectly.	<ul style="list-style-type: none"> <li>●Check the temp sensor.</li> <li>→Did the wire broke or disconnect?</li> </ul>
Fuel gauge does not appear or appear incorrectly.	<ul style="list-style-type: none"> <li>●Check your fuel tank.</li> <li>→Is there any fuel inside the tank?</li> <li>●Check the wiring harness.</li> <li>→Is the wire connected properly?</li> <li>●Check the setting.</li> <li>→Refer to the manual 4-9.</li> </ul>
The clock is incorrect.	<ul style="list-style-type: none"> <li>●Do you connect the wires correctly.</li> <li>→Check the positive wire (Red) connected to the battery, and the main positive wire (Brown) connected to the main switch.</li> </ul>

※If the problems still can't be solve, please contact your local distributor to get assistance.