



● Thank you for purchasing our product. Before installing, please read the instruction carefully and keep it for future reference.

⚠ Attention!

- For installation, please follow the steps described in manual. Any damage caused by wrong installation shall be imputed to the users.
- Don't break or modify the wire. To avoid the short circuit, please don't pull the wire when installing.
- Do not disassemble or change any parts excluding the manual description.
- The interior examination or maintenance should be executed by our professionals.

◎ MARK MEANING:

NOTE You could get the installation details from the information behind the mark.

⚠ Some processes must be followed to avoid the affection caused by wrong installation.

⚠ **WARNING!** Some processes must be followed to avoid damages to yourself or the public.

⚠ **CAUTION!** Some processes must be followed to avoid the damage to the vehicle.

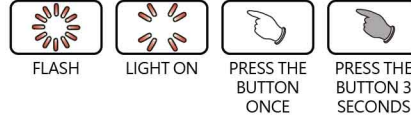

1-1 Accessories

1 Meter X1	2 Main wiring X1	3 Temp sensor wire X1	4 TH-01 water temp sensor X1
5 Active speed sensor X1	6 RPM wire (TYPE A) X1	7 RPM wire (TYPE B) X1	8 M8/S type speed sensor bracket X1
9 M10/S type speed sensor bracket X1	10 M5X5Lmm Hexagon screw X2	11 2.5mm Allen key X1	12 3mm Allen key X1
13 Meter bracket X1	14 M4X12Lmm screw X3	15 M5 washer X3	16 M6X35Lmm screw X2
17 M8X30Lmm screw X2	18 M6 aluminum screw bush X2	19 M8 aluminum screw bush X2	20 M6 gasket X2
21 M8 gasket X2			

NOTE Contact your local distributor, if the items received in the box are not the same as the items listed above.

1-2 Optinal Accessories

1 L type speed sensor bracket	2 Oil temp sensor adapter M12 X P1.5 X 15L M14 X P1.25 X 15L M14 X P1.5 X 15L M16 X P1.5 X 15L M18 X P1.5 X 15L M20 X P1.0 X 15L M20 X P1.5 X 15L	3 Water temp sensor adapter M14 M16, M18 M22, M26 mm	4 Signal connect wire
5 Oxygen sensor (WALKER, SMG)	6 Bung cap	7 Sensor bung	

NOTE Contact your local distributor, if the items received in the box are not the same as the items listed above.

2-1 Wiring Installation Instructions

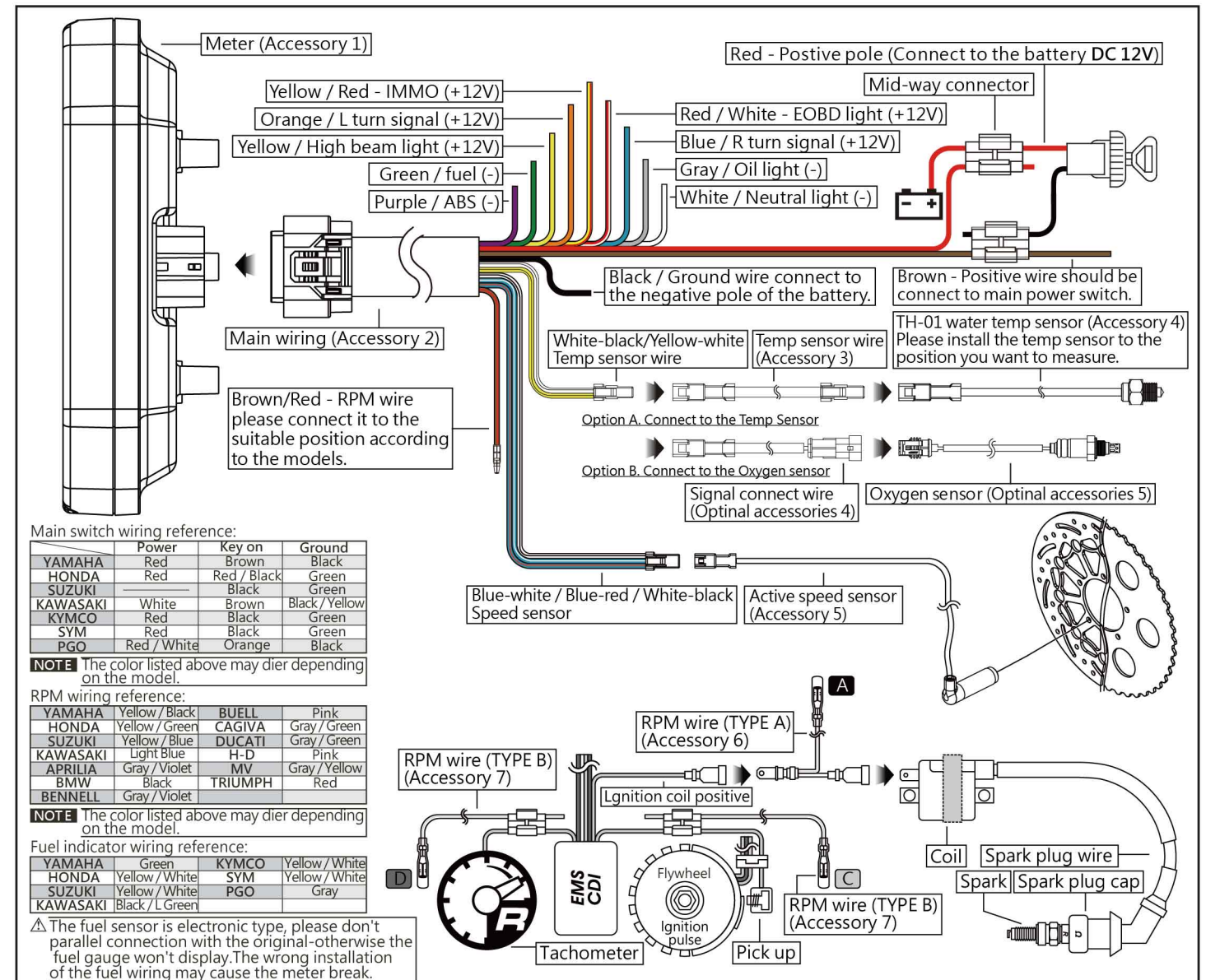

NOTE The temperature will disappear if you do not install & connect the temperature sensor to the meter.

NOTE When connecting the power wiring, follow the instruction above. If you connect the red & brown wire in parallel this will cause the meter to work improperly.

⚠ The RPM wire installation

- Connect the RPM wire (Type A) on the spark plug wire by connecting the male and female connectors.
- Connect the RPM wire (Type A) to the pick up sensor.
- Parallel the RPM wire (Type A) with the original tachometer signal wire. (This method is available only when the original speedometer comes with a tachometer on it. You could get the RPM wire information from the service manual for your bike.)
- Use the method mentioned above to install the RPM wire and then connect the ground wire to the negative pole of the battery.
- Use the method mentioned above to install the RPM wire and then connect the ground wire to the frame body or the engine. (Make sure that the ground is a good ground.)

The best signal source will be in order as C>B>A, we will suggest you to check different ways if you have problems to get the RPM signal.

2-2 Installation Instruction

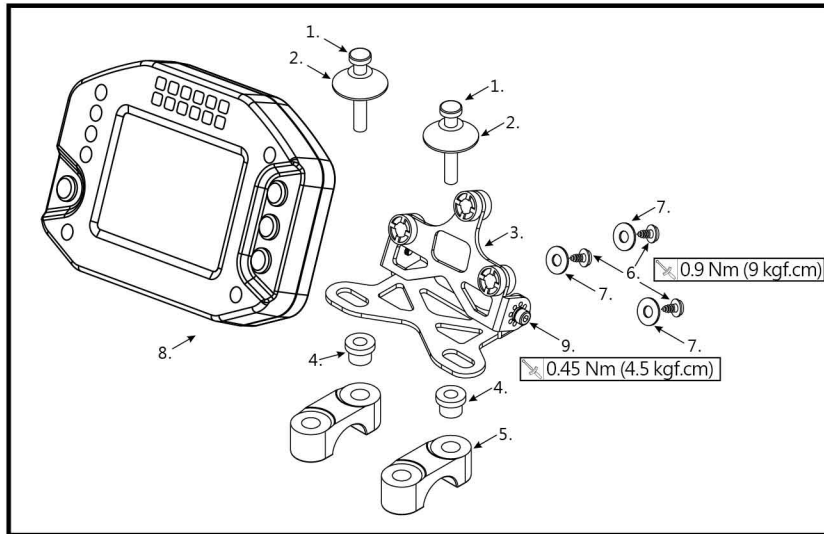

When installing, please follow the steps below.

1. M6 or M8 screw X2 (Accessory 16.17)
2. M6 or M8 aluminum screw bush X2 (Accessory 18.19)
3. Bracket (Accessory 13)
4. M6 or M8 gaske X2 (Accessory 20.21)
5. Handle bar bracket

NOTE You could also install it (meter bracket) on the original meter bracket.

6. M4 screw X3 (Accessory 14) $\times 0.9 \text{ Nm (9 kgf.cm)}$
7. M5 washer X3 (Accessory 15)
8. Meter (Accessory 1)
9. Meter bracket micro-adjustment screw $\times 0.45 \text{ Nm (4.5 kgf.cm)}$

NOTE You could also install it (meter bracket) on the original meter bracket.

MOTO / SCOOTER S type Speed Sensor Bracket Instruction

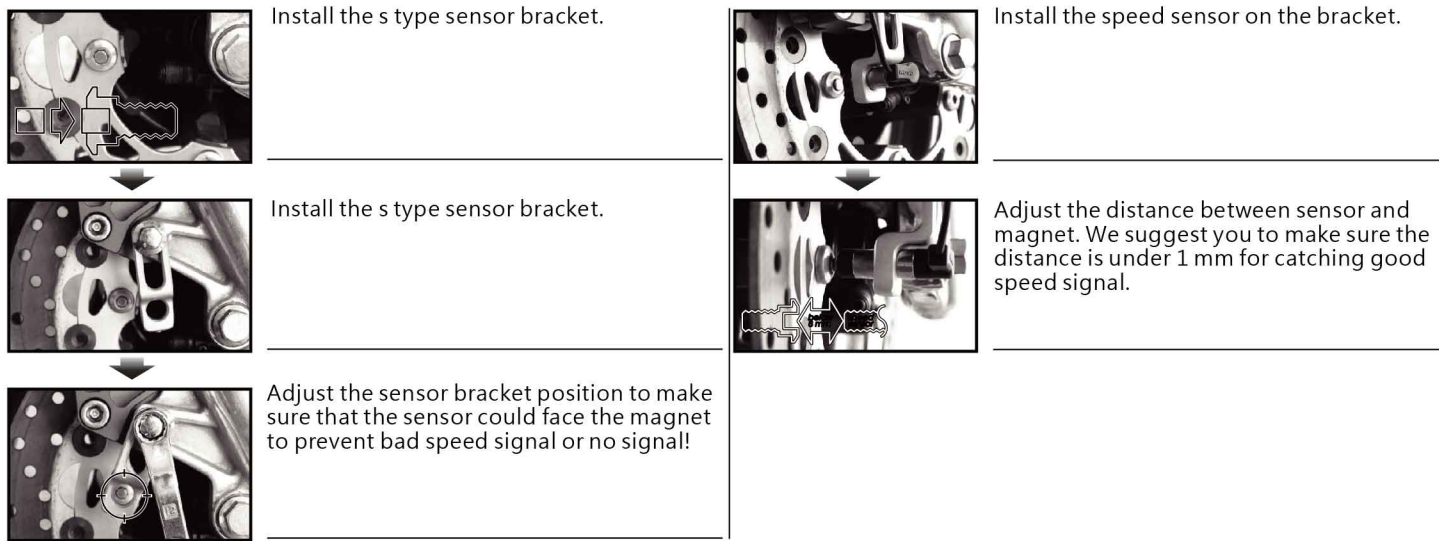

MOTO / SCOOTER L type Speed Sensor Bracket Instruction

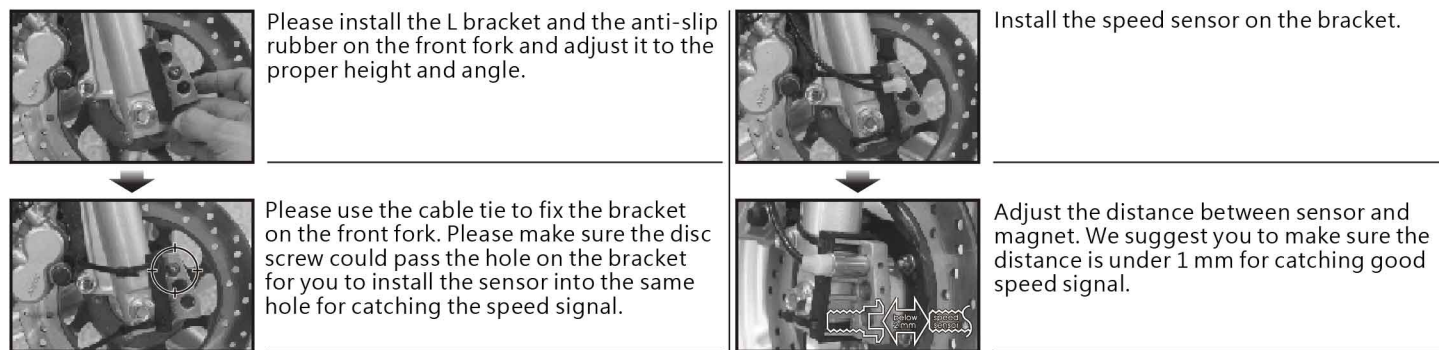

PS. Target!

The active speed sensor could be installed by the metal parts to detect the speed.

- EX. 1 The disc screw.
EX. 2 The disc to detect the disc gap. (Please make sure the distances between the gaps are the same in advance to avoid wrong speed signal.)
EX. 3 The sprocket to detect the disc gap. (Please make sure the distances between the gaps are the same in advance to avoid wrong speed signal.)
EX. 4 Rear disc - detect the gap between the disc.
We will suggest you to catch the speed from the disc screws. The more the sensor points are, the better the speed accuracy is. The maximum sensor points the speed sensor could detect is 20 points per turn.

⚠ After installation, please use your hand to turn the tire to see if everything is ok. The LED on the active speed sensor will light up once the signal is detected.

EX. 1

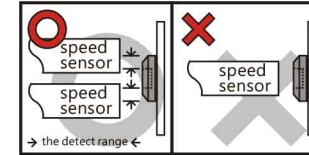

The hexagon socket disc screw
The best detect area: The edge of the hexagon socket screw.
⚠ Please don't catch the signal from the middle hole of the hexagon socket screw to avoid wrong signal.

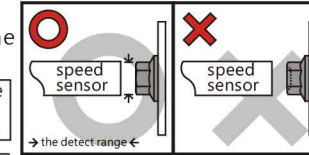

The hexagon screw
The best detect area: The middle of the screws.
⚠ Some hexagon screw center is with a small hole in the center in this case, we will suggest you to catch the signal from the edge of the screw like the hexagon socket screw.

EX. 2, 4

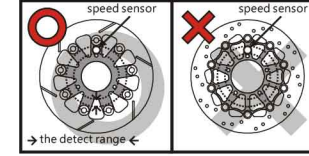

The disc
The best detect area: Please detect the speed signal from the gaps of the disc.
⚠ Please note that there are discs with the gaps in different difference, and this method will not work on it!

EX. 3

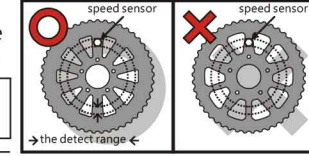

The sprocket
The best detect area: Please detect the speed signal from the gaps of the sprocket.
⚠ Please note that there are sprockets with the gaps in different difference, and this method will not work on it!







3-1 Button Definition & Button Instruction



3-2 Overview

- Tachometer (Level)**
 - Display range : 0 ~ 9,000、12,000、15,000、18,000、20,000 RPM
- Tachometer (Digital)**
 - Display range : 0 ~ 20,000 RPM
 - Display unit : 100 RPM
- Fuel Level**
 - Display range : 0 ~ 100 %
 - Setting range : 100 Ω、250 Ω、510 Ω、1200Ω、SW、Custom
- Indicator light color**
 - Neutral (green light) N
 - Engine (yellow light) E
 - Motor oil (red light) M
 - High beam light (blue light) H
 - Indication light (green light) I
 - IMMO (red light) IMMO
 - ABS (yellow light) ABS
- Speeding Warning**
 - Display range : 30 ~ 180 km/h (20 ~ 112 MPH)
 - Display unit : 1 km/h (MPH)
- Shift Light Warning**
 - Display range : 0 ~ 20,000 RPM
 - Display unit : 100 MPH
- Gear Meter**
 - Display range : N、1~6
- Speedometer**
 - Display range : 0 ~ 360 km/h (0 ~ 223MPH)
 - Display unit : km/h (MPH) Switchable
- Thermometer**
 - Display unit : °C、°F Switchable
 - Display range : 0 ~ 250 °C (32 ~ 482 °F)
 - Display unit : 0.1 °C (°F)
- A/F ratio meter**
 - Display range : 12.1 ~ 16.8
- Clock**
 - Display range : 24 H
- Volt**
 - Display range : DC 8.0 ~ 18.0 V
 - Display unit : 0.1 V
- Odometer**
 - Display range : 0 ~ 99,999 km (mile) return to zero upon exceed.
 - Display unit : 1 km (mile)
- Trip meter A、B**
 - Display range : 0.0 ~ 9999.9 km (mile) return to zero upon exceed.

3-3 Specifications

● Speedometer	Display range : 0 ~ 360 km/h (0 ~ 223 MPH) Display unit : 1 km/h (MPH) for alternative	● Clock	Display range : 24 H
○ Display internal	<0.5 Second	● Digital Volt meter	Display range : DC 8.0 ~ 18.0 V Display unit : 0.1 V
○ Odometer	Display range : 0 ~ 99,999 km/h (MPH) reset automatically after 99,999 km (MPH). Display unit : 1 km/h (MPH)	● Target speed timer	Setting range : 30 ~ 360 km/h (20 ~ 223 MPH) Setting unit : 5 km (MPH)
○ Trip meter A、B	Display range : 0 ~ 9999.9 km/h (MPH) reset automatically after 9999.9 km (MPH). Display unit : 0.1 km/h (MPH)	● Target distance timer	Setting range : 50 ~ 1,500 M (1/32 ~ 30/32 MPH) Setting unit : 50 M (1/32 MPH)
○ Speeding warning light	Setting range : 0 ~ 90 km/h (0 ~ 56 MPH) Setting unit : 1 km/h (MPH)	● Top speed timer	The record including Speed : 0 ~ 360 km/h (0 ~ 225 MPH) Distance : 0 ~ 999 M (0~3,280 feet) RPM : 0 ~ 20,000 RPM Display Range Timer : 9 : 59" 99
○ Top speed record (MAX)	Display range : 0 ~ 360 km/h (0 ~ 223 MPH) Display unit : 1 km/h (MPH)	● Display & Backlight	Setting range : Time setting switchover (Positive and Negative (nighttime function is turned off when Display of the Main Screen) the before and after time is the same)
○ Tire circumference	Display range : 300~2,500 mm Display unit : 1 mm • Sensor point : 1 ~ 60	● Back light color	Setting range : White、Green、Light Blue、Blue、Purple、Red、Orange、Yellow
● Gear Meter	Display range : N、1~6、OFF	○ Liquid Crystal Concentration	Setting range : 1/3(Darkest) ~ 3/3(Brightest)
● Digital Tachometer	Display range : 0 ~ 20,000 RPM Display unit : 100 RPM	○ Back light brightness light	Setting range : 1/5(Darkest) ~ 5/5(Brightest) ; Separate setting for daytime and nighttime
● Level Tachometer	Display range : 0 ~ 9,000、12,000、15,000、18,000、20,000 RPM	○ Brightness (LED Bar)	Setting range : 1/5(Darkest) ~ 5/5(Brightest) ; Separate setting for daytime and nighttime
○ RPM shift light	Setting range : 3,000 ~ 20,000RPM	● Supply voltage	DC 12 V
○ Max RPM record	Display range : 0 ~ 20,000 RPM	● Effective temperature range	-10 ~ +60 °C
○ RPM Signal (For Fuel Injection)	Setting range : 0.5, 1 ~ 24	● Meter standard	JIS D 0203 (S2)
● Thermometer	Display range : °C & °F for alternative	● Meter size	129 x 85.3 x 40.5 mm
○ Digital Thermometer	Display range : 0 ~ 250.0 °C (32.0 ~ 482.0 °F) Setting range : 1 °C (°F)	● Meter weight	Around 151 g
○ Temperature warning	Setting range : 50 ~ 250.0 °C (122.0 ~ 482.0 °F) Display unit : 1 °C (°F)	● Indicator light color	Neutral (green light)  Engine (yellow light)  Motor oil (red light)  High beam light (blue light)  Indication light (green light)  IMMO (red light)  ABS (yellow light) 
○ Top temperature (MAX)	Display range : 0 ~ 250.0 °C (32.0 ~ 482.0 °F)	NOTE Design and specifications are subject to change without notice.	
● A/F ratio meter	Display range : 12.1 ~ 16.8 Display range : 0.1		
● Level Fuel	Display range : 6 Level Display unit : 16.6 % each segment		
○ Fuel resistance setting	Display range : 100、250、510、1200、SW、Learning		
○ Low Fuel warning	Setting range : 0 ~ 3/6 格 Display unit : 11/6 (At)/lower than the setting value, warning FI light lit, fuel level glitter.		
○ Motor oil maintence	Setting range : 500 ~ 16,000 km (312 ~ 10,000 mile)		
○ ABS indicator	Setting range : ON/OFF		

3-4 Meter size

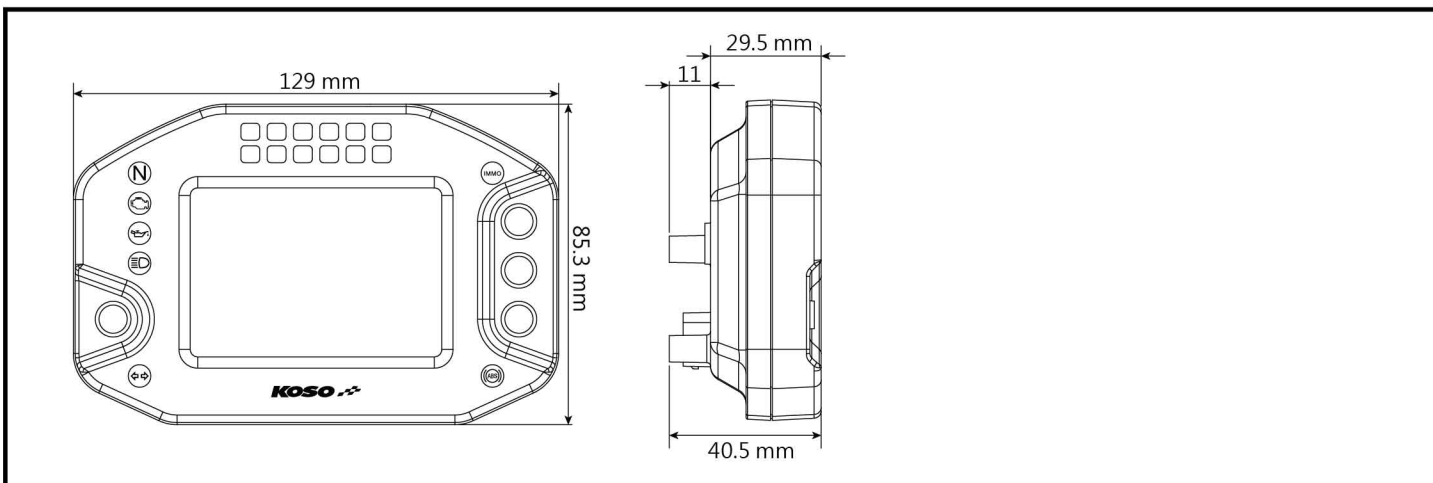



3-5-1 Main Screen Switchover Instruction

● In the ODO screen, press the  button to enter the Trip A screen.

● In the Trip A screen, press the  button to enter the Trip B screen.

● In the Trip B screen, press the  button to enter the Max. record screen.

● In the Max. record screen, press the  button to go back to the ODO screen.

● Press the  button for 3 seconds to reset Max. record screen.

● In the ODO screen.

3-5-2 Rapid Switchover-Target distance timer / Top speed timer / Target speed timer

● In the ODO screen, press the  button for 3 seconds to enter the Target distance timer screen.

● Target distance timer screen (D), press the  button to enter the Top speed timer screen (T).

● Press the  button for 3 seconds to reset record screen.

● Top speed timer screen (T), press the  button to enter the Target speed timer (S).

● Press the  button for 3 seconds to reset record screen.

● Target speed timer (S), press the  button to go back to the ODO screen.

● Press the  button for 3 seconds to reset record screen.

● In the ODO screen.

3-6 The Settings Screen Description

- In the main screen, press the button for 3 seconds to enter the Target distance timer screen (D) screen.
- In the Target distance timer screen (D) screen, press the button for 3 seconds to enter into the settings screen.
- Press the button to enter the
- 1 Clock 2 Unit (Speed · Temperature) 3 LED BAR Nighttime 4 Backlight 5 LED BAR Brightness 6 Tire circumference · sensing point settings
- 7 LED BAR Overspeed Range 8 Overspeed Warning 9 Gear 10 RPM input pulse · signal impulse settings · Level Digital tachometer settings
- 11 LED BAR Over-Running Range 12 Over-Running Warning 13 Temperature Warning 14 Fuel Gauge Resistance 15 Low Fuel Warning
- 16 Motor Oil Maintenance 17 A/F Ratio Meter 18 Volt Warning 19 ABS Warning 20 Target Speed Timer 21 Target Distance Timer 22 Recording Order
- 23 ODO
- Press the button to go back to the setting screen.
- NOTE** If you enter the settings screen for 30 seconds and don't press the button, it will go back to the main screen automatically.

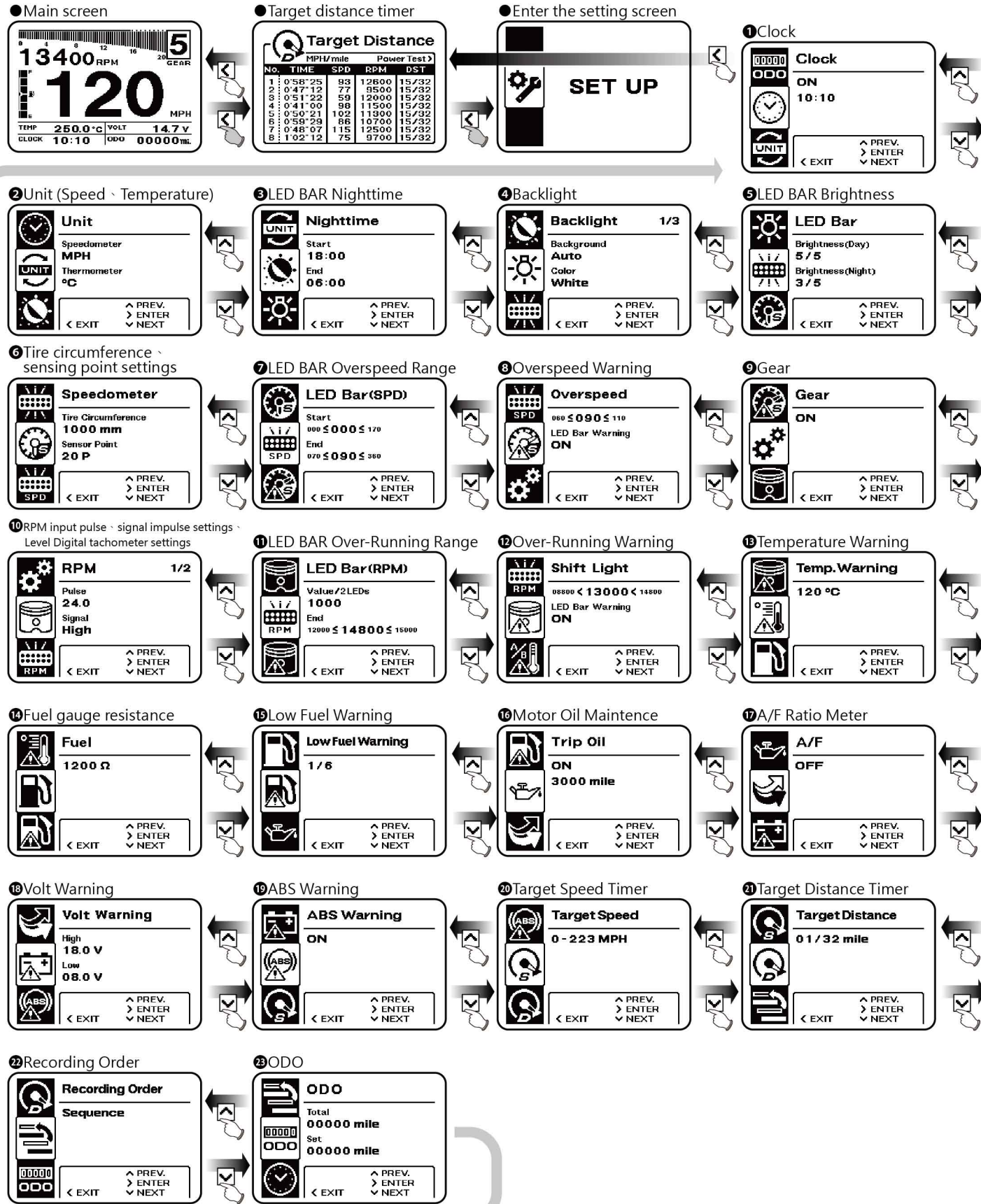

4-1 Clock Setting

- Press the button to enter the clock setting.
- Example : To set time (minute) as 10 minutes.
 - Press the or button to choose the setting number.
 - ⚠ Now the setting value is flashing!
 - NOTE** Setting range : 00~59 minutes.
 - NOTE** Default value : 59
- EX : Set minute from 0 to 10 minutes.
 - Press the button to go back to the time setting.
- Example : Changing the ON.
 - Press the or button to choose the setting number.
 - Press the button to enter time adjustment hour setting.
 - ⚠ Now the setting value is flashing!
 - NOTE** Setting range : ON · OFF
 - NOTE** Default value : ON
- Example : To set time (hour) as 18 hours.
 - Press the or button to choose the setting number.
 - ⚠ Now the setting value is flashing!
 - NOTE** The order of cursor movement is : hour → minute.
 - NOTE** Default value : 12
- EX : Set hour from 12 : 00 to 18 : 00.
 - Press the button to enter time adjustment minute setting.

4-2 Speed · Temperature Unit Setting

- Press the button to enter the Speed · Temperature unit settings screen.
- Example : You want to set the °F.
 - Press the or button to choose the setting number.
 - ⚠ Now the setting value is flashing!
 - NOTE** Setting range : °C · °F
 - NOTE** Default value : 59
- EX : The Temperature unit setting is changed from °C to °F.
 - Press the button to go back to the Speed · Temperature unit settings screen.
- Example : You want to set the MPH.
 - Press the or button to choose the setting number.
 - ⚠ Now the setting value is flashing!
 - NOTE** Setting range : km/h · MPH
 - NOTE** Default value : km/h
 - NOTE** Setting The odometer & trip meter will change together with the speed unit.
- EX : The Speed unit setting is changed from km/h to MPH.
 - Press the button to enter time Temperature unit setting.

4-3 LED Bar Nighttime Setting

● Press the **[ENTER]** button to enter the LED Bar Nighttime setting screen.



● Example : To set LED Bar nighttime (hour) starting time to 19.

● Press the **[UP]** or **[DOWN]** button to choose the setting number.

⚠ Now the setting value is flashing!

NOTE Default value : 18

● EX : Setting LED Bar nighttime (hour) starting time from 18 to 19.

● Press the **[ENTER]** button to enter the LED Bar nighttime (minute) starting time setting.



● Example : To set LED Bar nighttime (minute) starting time to 30.

● Press the **[UP]** or **[DOWN]** button to choose the setting number.

⚠ Now the setting value is flashing!

NOTE Default value : 00

● EX : Setting LED Bar nighttime (minute) starting time from 0 to 30.

● Press the **[ENTER]** button to enter the LED Bar nighttime (hour) ending time setting.



● Example : To set LED Bar nighttime (hour) ending time to 05.

● Press the **[UP]** or **[DOWN]** button to choose the setting number.

⚠ Now the setting value is flashing!

NOTE Default value : 06

⚠ If the starting time and the ending time setting of the night-time mode is the same, means the night-time mode is turned off.

NOTE When the time reaches the scope of the night-time mode, the brightness of the LED Bar and the back light will be adjusted to the night-time brightness set by the user. When the time falls out of such scope of time, the LED Bar is fully light.

● EX : Setting LED Bar nighttime (hour) ending time from 6 to 5.

● Press the **[ENTER]** button to enter the LED Bar nighttime (minute) ending time setting.



● Example : To set LED Bar nighttime (minute) ending time to 30.

● Press the **[UP]** or **[DOWN]** button to choose the setting number.

⚠ Now the setting value is flashing!

NOTE Default value : 00

● EX : Setting LED Bar nighttime (minute) ending time from 0 to 30.

● Press the **[ENTER]** button to go back to the LED Bar nighttime setting.



● Press the **[DOWN]** button to enter next operation setting.

4-4 Backlight Instruction (Positive/Negative Display, Color, Contrast, Brightness-Daytime, Brightness-Nighttime)

● Press the **[ENTER]** button to enter the Backlight setting screen.



4-4-1 Backlight - Positive/Negative Display

● Example : Set the backlight to positive display.

● Press the **[UP]** or **[DOWN]** button to choose the setting number.

⚠ Now the setting value is flashing!

NOTE Setting range : Auto · Black · White

NOTE Default value : White

NOTE

- 1.) Select Auto and based on the nighttime period of LED BAR, "positive display" during daytime and "negative display" during nighttime.
- 2.) Select Black, full time "negative display."
- 3.) Select White, full time "positive display."

● EX : Setting backlight from Auto to White.

● Press the **[ENTER]** button to enter the Backlight color setting.



4-4-2 Backlight Color setting

● Example : To set Backlight color to orange.

● Press the **[UP]** or **[DOWN]** button to choose the setting number.

⚠ Now the setting value is flashing!

NOTE Default value : White

NOTE Setting range : White · Green · Light Blue · Blue · Purple · Red · Orange · Yellow

NOTE The backlight brightness will change immediately after you set the value.

● EX : Setting Backlight color from white to orange.

● Press the **[ENTER]** button to enter the Backlight contrast setting.

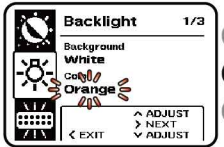

4-4-3 Backlight Contrast

● Example : To set Backlight contrast to 2/3.

● Press the **[UP]** or **[DOWN]** button to choose the setting number.

⚠ Now the setting value is flashing!

NOTE Default value : 3/3

NOTE Setting range : 1/3(Lightest)~3/3(Darkest)



● EX : Setting Backlight contrast from 3/3 to 2/3.

● Press the **[ENTER]** button to enter the Backlight brightness - Daytime brightness setting.



4-4-4 Backlight brightness - Daytime

● Example : To set Backlight brightness - Daytime to 3/5.

● Press the **[UP]** or **[DOWN]** button to choose the setting number.

⚠ Now the setting value is flashing!

NOTE Default value : 5/5

NOTE Setting range : 1/5(darkest)~5/5(brightest)

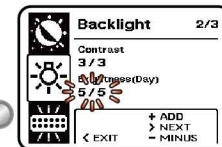

● EX : Setting Backlight brightness - Daytime from 5/5 to 3/5.

● Press the **[ENTER]** button to enter the Backlight brightness - Nighttime brightness setting.



4-5 LED BAR Brightness Setting

● Press the **[ENTER]** button to enter the LED BAR Brightness setting screen.



● Example : To set LED BAR Brightness - Daytime to 3/5.

● Press the **[UP]** or **[DOWN]** button to choose the setting number.

⚠ Now the setting value is flashing!

NOTE Default value : 5/5

NOTE Setting range : 1/5(darkest)~5/5(brightest)



● EX : Setting LED BAR Backlight brightness - Daytime from 5/5 to 3/5.

● Press the **[ENTER]** button to enter the LED BAR Backlight brightness - Nighttime brightness setting.



4-4-5 Backlight Brightness - Nighttime

● Example : To set Backlight brightness - nighttime to 5/5.

● Press the **[UP]** or **[DOWN]** button to choose the setting number.

⚠ Now the setting value is flashing!

NOTE Default value : 5/5

NOTE Setting range : 1/5(darkest)~5/5(brightest)



● EX : Setting Backlight brightness - nighttime from 3/5 to 5/5.

● Press the **[ENTER]** button to go back to the Backlight brightness - Nighttime brightness setting.



4-4-5 Backlight Brightness - Nighttime

● Press the **[DOWN]** button to enter next operation setting.

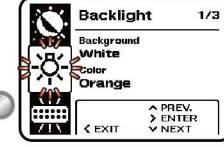

● Example : To set LED BAR Backlight brightness - nighttime to 5/5.

● Press the **[UP]** or **[DOWN]** button to choose the setting number.

⚠ Now the setting value is flashing!

NOTE Default value : 5/5

NOTE Setting range : 1/5(darkest)~5/5(brightest)



● EX : Setting LED BAR Backlight brightness - nighttime from 3/5 to 5/5.

● Press the **[ENTER]** button to go back to the LED BAR Backlight brightness - Nighttime brightness setting.



● Press the **[DOWN]** button to enter next operation setting.



4-6 The Tire Circumference And Sensor Point Settings

● Press the **[▶]** button to enter the into the tire circumference and sensor point settings screen.

● EX. Now the setting is changed from 1,000 mm to 1,300 mm.
● Press the **[▶]** button to enter the sensor point settings screen.

● Example : To set tire circumference to 1,300 mm.
● Press the **[▶]** button to move to the digit you want to set.
⚠ Now the setting value is flashing!

● Example : To set the sensor point to 06 P.
● Press the **[▶]** button to move to the digit you want to set.
⚠ Now the setting value is flashing!

CAUTION!
● Please measure the tire circumference (the tire you will install the sensor on) and make sure the number of magnet sensor point (You could install the magnet into the disc screw or the sprocket screw.)
● The speed displayed on the meter will be affected by the settings, make sure the setting number is correct before you make the final setting.

NOTE Default value : 1P
NOTE Setting range : 01P ~ 20P

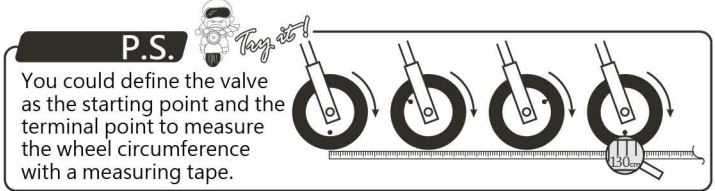

● Press the **[▲]** or **[▼]** button to choose the setting number.

● EX. Now the setting is changed from 01 P to 06 P.
● Press the **[▶]** button to go back to the tire circumference and sensor point settings screen.

● Press the **[▲]** or **[▼]** button to choose the setting number.
NOTE Setting range : 300 ~ 2,500 mm
NOTE Default value : 1,000 mm

● Press the **[✓]** button to enter next operation setting.

4-7 LED BAR Overspeed Range Setting

● Press the **[▶]** button to enter the into the LED BAR Overspeed range setting.

● Example : To set LED BAR overspeed ending range to 120 km/h.
● Press the **[▲]** or **[▼]** button to choose the setting number.
NOTE Default value : 90 km/h

● Example : To set LED BAR overspeed starting range to 50 km/h.
● Press the **[▶]** button to move to the digit you want to set.
⚠ Now the setting value is flashing!

● EX. Now the setting is changed from 50 km/h to 120 km/h.
● Press the **[▶]** button to go back to the LED Bar overspeed range main screen.

● Press the **[▲]** or **[▼]** button to choose the setting number.
NOTE Default value : 0 km/h

● Press the **[✓]** button to enter next operation setting.

● EX. To set LED BAR overspeed starting range from 0 km/h to 50 km/h LED BAR.
● Press the **[▶]** button to enter the LED BAR overspeed ending range setting.

4-8 Overspeed Warning Setting

● Press the **[▶]** button to enter the into the LED BAR Overspeed warning setting.

● Example : To set LED BAR overspeed warning scope to OFF.
● Press the **[▲]** or **[▼]** button to choose the setting number.
⚠ Now the setting value is flashing!
NOTE Default value : ON
NOTE Setting range : ON ~ OFF

● Example : To set overspeed warning range to 90 km/h.
● Press the **[▶]** button to move to the digit you want to set.
⚠ Now the setting value is flashing!

● EX. Now the setting is changed from ON to OFF.
● Press the **[▶]** button to go back to the LED Bar Over-running warning scope main screen.

● Press the **[▲]** or **[▼]** button to choose the setting number.
NOTE Default value : 60 km/h
NOTE Setting range : 0 ~ 90 km/h

● Press the **[✓]** button to enter next operation setting.

● EX. To set overspeed warning range from 50 km/h to 90 km/h.
● Press the **[▶]** button to enter the LED BAR overspeed flashing scope setting.

4-9 Gear Meter Setting

● Press the **[▶]** button to enter the into the Gear meter setting.
● Press the **[▶]** button to enter the into the Gear meter setting.

● EX. Now the setting is changed from ON to OFF.
● Press the **[▶]** button to go back to the gear learning setting main screen.

● Example : To set Gear meter setting to OFF.
● Press the **[▲]** or **[▼]** button to choose the setting number.
NOTE Default value : ON
⚠ Now the setting value is flashing!

● Press the **[✓]** button to enter next operation setting.

⚠ If ON (turned on) is selected, enter the gear learning setting, please refer to 4-9-1.

4-9-1 Gear Learning Setting

● Gear Learning Setting.
⚠ **CAUTION!** Before setting, be sure to put your motor in Neutral to avoid error detection
⚠ **CAUTION!** " Fail" on the screen means error detection, please re-set Gear-Learn.

● After reaching and finishing Gear 6, please wait for a few seconds to end Gear-Learn and return to the settings screen.

⚠ **CAUTION!** If gear learning is not required, press **[◀]** button to cancel the gear learning.
● When N→1 appears, please change to Gear 1 to ride.
When Gear 1 is detected, 1→2 appears and then change to Gear 2.

● Press the **[✓]** button to enter next operation setting.

- Please change to Gear 2.
- Please change to Gear 3.
- Please change to Gear 4.
- Please change to Gear 5.
- Please change to Gear 6.

4-10 RPM input pulse & signal impulse & Level Tachometer settings

● Press the **[ENTER]** button to enter the RPM input pulse & signal impulse & Level Tachometer settings.

● Example : You want to set the RPM input pulse to 2 (4 Stroke, 4 piston).
● Press the **[UP]** or **[DOWN]** button to choose the setting number.
⚠ Now the setting value is flashing!

NOTE Default value : P-1

NOTE Setting range : P-0.5 · 1 · 1.5 · 2 · 2.5 · 3 · 4 · 5 · 6 · 9 · 10 · 11 · 12 · 17 · 18 · 23 · 24 · 34 · 36

The setting value	The corresponding stroke and pistons number.	The corresponding RPM signal number per ignition.
0.5	4C-1P	2 RPM signals per 1 ignition.
1.0	2C-1P 4C-2P	1 RPM signal per 1 ignition.
2.0	2C-2P 4C-4P	1 RPM signal per 2 ignition.
3.0	2C-3P 4C-6P	1 RPM signal per 3 ignition.
4.0	2C-4P 4C-8P	1 RPM signal per 4 ignition.
5.0	4C-10P	1 RPM signal per 5 ignition.
6.0	2C-6P 4C-12P	1 RPM signal per 6 ignition.

⚠ CAUTION!

Most of the 4-cycle bikes with one single piston are igniting once every 360 degree, so the setting should be the same as the bike with 2-cycle and one piston engine.

● EX. Now the setting is changed from P1.0 to P2.0.
● Press the **[ENTER]** button to enter the Signal impulse settings screen.

4-11 LED BAR Over-Running Range



Please scan QR code for information.

4-13 Temperature Warning Settings

● Press the **[ENTER]** button to enter the into the Temperature Warning settings.

● Example : You want to set the Temperature warning to 120 °C.
● Press the **[ENTER]** button to enter the Signal impulse settings screen.
⚠ Now the setting value is flashing!

NOTE Default value : 90 °C (194 °F)

NOTE Setting range : 50 ~ 250.0 °C (122.0 ~ 482.0 °F)

4-14 Fuel Gauge Resistance Settings



Please scan QR code for information.

● Example : You want to set the Signal impulse at Lo.
● Press the **[UP]** or **[DOWN]** button to choose the setting number.
⚠ Now the setting value is flashing!

NOTE Default value : High

NOTE Setting range : High · Low

● EX. Now the setting is changed from Hi to Lo.
● Press the **[ENTER]** button to enter the Level tachometer settings screen.

● Example : You want to set the Level tachometer to 12,000 RPM..
● Press the **[UP]** or **[DOWN]** button to choose the setting number.
⚠ Now the setting value is flashing!

NOTE Default value : 9,000 RPM

NOTE Setting range : 9,000 · 12,000 · 15,000 · 18,000 · 20,000 RPM ·

● EX. Now the setting is changed from 9,000 RPM to 15,000 RPM.
● Press the **[ENTER]** button to go back to the RPM input pulse & signal impulse & Level Tachometer settings screen.

● Press the **[ENTER]** button to enter next operation setting.

4-12 Over-Running Warning



Please scan QR code for information.

4-15 Low Fuel Warnings Settings

● Press the **[ENTER]** button to enter the Low Fuel warning settings screen.

● Example : You want to set the Low Fuel warning to 3(60 %).
● Press the **[UP]** or **[DOWN]** button to choose the setting number.
⚠ Now the setting value is flashing!

NOTE Default value : 1 levels

NOTE Setting range : 1 ~ 3 levels (20 ~ 60 %)

● EX. Now the setting is changed from 1(20%) to 3(40%).
● Press the **[ENTER]** button to go back to the Low Fuel warning settings screen.

● Press the **[ENTER]** button to enter next operation setting.

4-16 Mileage maintenance settings

● Press the **[ENTER]** button to enter the Mileage maintenance settings screen.

● Example : You want to set Mileage maintenance to (ON).
● Press the **[UP]** or **[DOWN]** button to choose the setting number.
⚠ Now the setting value is flashing!

NOTE Setting range : ON · OFF

● EX. Now the setting is changed from OFF to ON.
● Press the **[ENTER]** button to enter the Mileage maintenance settings screen.

● Example : You want to set the Mileage maintenance to 1,200 mile.
● Press the **[UP]** or **[DOWN]** button to choose the setting number.
⚠ Now the setting value is flashing!

NOTE Default value : 500 km

NOTE Setting range : 500~16,000 km (312 ~ 10,000 mile) ·
Setting unit : 100 km (mile) ·

● EX. Now the setting is changed from 0,000 mile to 10,000 mile.
● Press the **[ENTER]** button to go back to the Mileage maintenance settings screen.

● Press the **[ENTER]** button to enter next operation setting.

4-17 A/F Ratio Warning Setting

● Press the **[ENTER]** button to enter the into the A/F Ratio Warning settings.

● Press the **[UP]** or **[DOWN]** button to choose the setting number.
● Select ON to enter the A/F ratio (rich/lean) warning setting.
⚠ Now the setting value is flashing!

NOTE Default value : OFF

NOTE Setting range : OFF · ON

NOTE Select OFF to return to the A/F ratio warning main screen.

● Example : To set the lean A/F ratio warning to 12.5.
● Press the **[UP]** or **[DOWN]** button to choose the setting number.
⚠ Now the setting value is flashing!

NOTE Default value : 15.5

NOTE Setting range : 12.4 ~ 17.4

● EX. Now the lean A/F ratio warning is changed from 14.0 to 12.5.
● Press the **[ENTER]** button to enter the lean A/F ratio warning setting screen.

● Example : To set the over-rich A/F ratio warning to 17.0.
● Press the **[UP]** or **[DOWN]** button to choose the setting number.
⚠ Now the setting value is flashing!

NOTE Default value : 14.5

NOTE Setting range : 12.4 ~ 17.4

● EX. Now the over-rich A/F ratio warning is changed from 14.9 to 17.0.
● Press the **[ENTER]** button to go back to the A/F ratio warning setting main screen.

● Press the **[ENTER]** button to enter next operation setting.

4-18 Volt warning level setting

● Press the **[]** button to enter the into the Volt warning level settings.

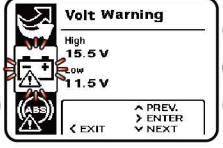

● Example : To set the overvoltage warning scope to 16.0 V.
● Press the **[]** or **[]** button to choose the setting number.
⚠ Now the setting value is flashing!
NOTE Default value : 15.5 V
NOTE Setting range : 8.1 ~ 18.0

● EX. Now the overvoltage warning is changed from 15.5 to 16.0.
● Press the **[]** button to enter the low voltage warning setting.

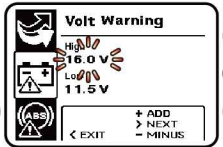

● Example : To set the low voltage warning setting to 11.0 V.
● Press the **[]** or **[]** button to choose the setting number.
⚠ Now the setting value is flashing!
NOTE Default value : 11.5 V
NOTE Setting range : 8.0 ~ 16.5

● EX. Now the low voltage warning is changed from 11.5 to 11.0.
● Press the **[]** button to go back low voltage warning main screen setting.

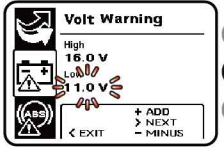

● Press the **[]** button to enter next operation setting.

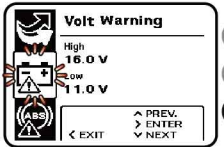

4-19 ABS Warning

● Press the **[]** button to enter the into the ABS Warning settings.



● Example : You want to set the ABS warning to OFF.
● Press the **[]** or **[]** button to choose the setting number.
⚠ Now the setting value is flashing!
NOTE Default value : ON
NOTE Setting range : ON - OFF



● EX. Now the ABS Warning setting is changed from ON to OFF.
● Press the **[]** button to go back ABS warning setting.

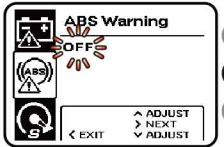

● Press the **[]** button to enter next operation setting.

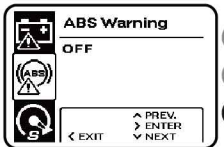

4-20 Target speed timer test settings

● Press the **[]** button to enter the into the Target speed timer test settings.



● Example : You want to set the Target speed timer test settings to 72 MPH.
● Press the **[]** button to enter the Signal impulse settings screen.
⚠ Now the setting value is flashing!
NOTE Default value : 100 km (62 MPH)
NOTE Setting range : 30 ~ 360 km/h (20 ~ 225 mph)



● Press the **[]** or **[]** button to choose the setting number.

● EX. Now the Target speed timer test is changed from 62 MPH to 72 MPH.
● Press the **[]** button to go back to Target speed timer test settings.



● Press the **[]** button to enter next operation setting.



4-21 Target distance timer test settings

● Press the **[]** button to enter the into the Target distance timer test settings.



● Example : You want to set the Target distance timer test settings to 06/32 mile.
● Press the **[]** or **[]** button to choose the setting number.
⚠ Now the setting value is flashing!
NOTE Default value : 50 m (1/32 mile)
NOTE Setting range : 50 ~ 1000 m (1/32 ~ 20/32 mile)



● EX. Now the Target distance timer test is changed from 05/32 mile to 06/32 mile.
● Press the **[]** button to go back to Target distance timer test settings.



● Press the **[]** button to enter next operation setting.



4-22 POWERTEST Score Sequent Settings

● Press the **[]** button to enter the into the POWERTEST Score sequent settings.



● Example : Set the POWERTEST results sequence to Best.
● Press the **[]** or **[]** button to choose the setting number.
⚠ Now the setting value is flashing!
NOTE Default value : Sequence
NOTE Setting range : Sequence - Bset

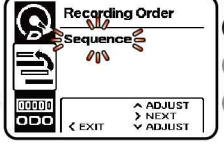

● EX. Now the POWERTEST Score sequent settings is changed from Sequence to Bset.
● Press the **[]** button to go back to POWERTEST Score sequent settings.



● Press the **[]** button to enter next operation setting.



4-23 Meter Odometer display

● Press the **[]** button to enter the into the Meter Odometer display screen.



● Example : The internal odometer display is 5 km.
⚠ This display is only for viewing current mileage on the meter.
NOTE Display range : 0 ~ 99,999 km (mile)

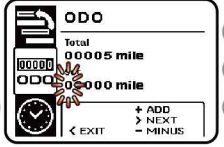

● Example : You want to set the External odometer to 10,000 km.
● Press the **[]** or **[]** button to choose the setting number.
⚠ Now the setting value is flashing!
NOTE Default value : 00,000 km (mile)
NOTE Setting range : 0~99,999 km (mile)

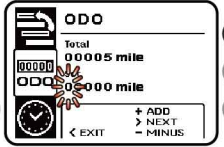

● EX. Now the setting is changed from 0 mile to 10,000 mile.
● Press the **[]** button to go back to the Meter Odometer display settings screen.



● Press the **[]** button to return to the Time screen.



5 Trouble Shooting

The following situationS do not indicate malfunction of the meter. Please check the following before taking it in for repairs.

Trouble	Check item	Trouble	Check item
The meter doesn't work when the power is on.	<ul style="list-style-type: none"> ● The power does not supply to the meter. → Please make sure the wiring is connected. The wiring and fuse are not broken. ● The battery is broken or the battery is too old to supply enough power (DC 12 V) to make the meter work. 	Tachometer does not appear or appears incorrectly.	<ul style="list-style-type: none"> ● Please check the RPM sensor wiring is connected correctly. → Please confirm whether the RPM wire is broken or fell off. ● Please check the spark plug is R type or not. If not, please replace the spark plug with the R type spark plug. ● Please check your setting. ● The setting may be wrong. → Please confirm the engine ignition angle setting. ● It is possible that the wiring is not properly connected. → Please confirm whether the wiring is properly installed. → Please confirm whether the original car signal line is broken.
Speedometer does not display or display error.	<ul style="list-style-type: none"> ● Check the voltage of your battery and makesure the voltage is over DC 12V. ● May be poor connection of the autometer harness or poor conduction. → Please make sure the autometer harness is connected correctly. ● May be setting error. → Please check the tire percentage setting. 	A/F ratio and temperature does not display or display error.	<ul style="list-style-type: none"> ● May be poor connection of the K-Line signal switch wiring. → Please make sure the K-Line signal switch wiring is connected correctly. ● The power does not supply to the meter. → Please check the clock setting.
Odometer and trip meter is not accumulated or display error.	<ul style="list-style-type: none"> ● May be poor connection of the autometer harness or normal conduction. → Please make sure the autometer harness is connected correctly. ● May be setting error. → Please check the tire percentage setting. 	The clock is incorrect.	<ul style="list-style-type: none"> ● The power does not supply to the meter. → Please check the clock setting.
Fuel meter does not display or display error.	<ul style="list-style-type: none"> ● May be poor connection of the harness. → Please make sure the wires are connected correctly. → Please check whether the original fuel signal wire is connected. 	The meter indicator did not display.	<ul style="list-style-type: none"> ● May be poor connection of the harness. → Please make sure the wires are connected correctly.

*If you can't resolve the problems according to the steps above, please contact your local distributors.